

LOAN COPY
Return to
TECHNICAL LIBRARY

EGG-TMI-5966 -R1
Revision 1

February 1983

Cy1

PATENT CLEARED

TMI-2 CORE EXAMINATION PROGRAM:
INEL FACILITIES READINESS STUDY

Thomas B. McLaughlin

M. L. Russell 6-8-83

Idaho National Engineering Laboratory
Operated by the U.S. Department of Energy

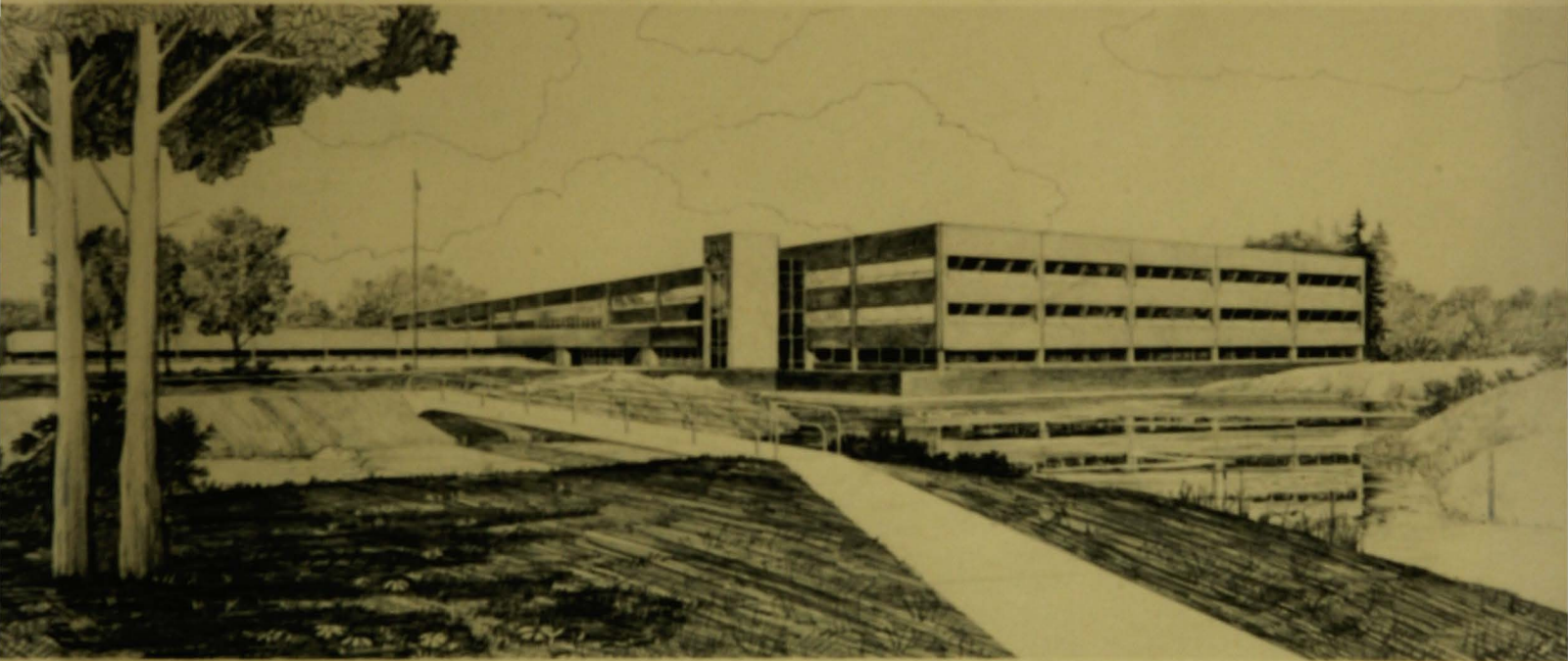

This is an informal report intended for use as a preliminary or working document

Prepared for the
U.S. DEPARTMENT OF ENERGY
Idaho Operations Office
Under DOE Contract No. DE-AC07-76ID01570

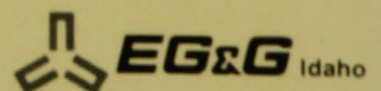

DISCLAIMER

This book was prepared as an account of work sponsored by an agency of the United States Government. Neither the United States Government nor any agency thereof, nor any of their employees, makes any warranty, express or implied, or assumes any legal liability or responsibility for the accuracy, completeness, or usefulness of any information, apparatus, product or process disclosed, or represents that its use would not infringe privately owned rights. References herein to any specific commercial product, process, or service by trade name, trademark, manufacturer, or otherwise, does not necessarily constitute or imply its endorsement, recommendation, or favoring by the United States Government or any agency thereof. The views and opinions of authors expressed herein do not necessarily state or reflect those of the United States Government or any agency thereof.

TMI-2 CORE EXAMINATION PROGRAM:
INEL FACILITIES READINESS STUDY

Thomas B. McLaughlin

February 1983

EG&G Idaho, Inc.
Idaho Falls, Idaho 83415

Prepared for the
U.S. Department of Energy
Idaho Operations Office
Under DOE Contract No. DE-AC07-761001570

.

.

ABSTRACT

This report reviews the capability and readiness of remote handling facilities at the Idaho National Engineering Laboratory (INEL) to receive, and store the TMI-2 core, and to examine and analyse TMI-2 core samples. To accomplish these objectives, the facilities must be able to receive commercial casks, unload canisters from the casks, store the canisters, open the canisters, handle the fuel debris and assemblies, and perform various examinations.

The report identifies documentation, including core information, necessary to INEL before receiving the entire TMI-2 core. Also identified are prerequisites to INEL's receipt of the first canister: costs, schedules, and a preliminary project plan for the tasks.

The information shows that all of the core receipt, storage, and examination operations can be performed at INEL. Some problems exist, but none are insolvable. Information was obtained from existing documentation, responses to specific questions, and interviews with hot cell personnel.

SUMMARY

The events leading up to the Three Mile Island Unit-2 (TMI-2) reactor accident, the accident itself, and the results of that accident have been the subject of national review by the nuclear industry and government agencies. As part of that review, samples of the core will be examined and analysed in order to understand the accident sequence and to form a data base for predicting and controlling nuclear fuel behavior during degraded core-cooling situations. The Idaho National Engineering Laboratory (INEL) will receive and store the TMI-2 core as part of the Core Activities Program administered by the Technical Support and Projects Office (TS&PO). Core examination efforts, encompassing selection, acquisition/isolation, storage, distribution and examination of core material samples, will also be administered by the TS&PO as part of the Core Activities Program. At least half of the examination and analysis effort will be performed by other laboratories, coordinated by and on samples provided through the TS&PO.

The INEL undertook an overall review of their remote handling facilities and determined capability, availability, and readiness to receive the TMI-2 core. In addition, a study was made that determined the administrative documentation needed prior to their receiving the core, the availability and condition of DOT-approved shipping casks, and accommodations for moving examination samples between site facilities. A preliminary project plan was also prepared from this information to demonstrate the feasibility of performing the core examination in the existing facilities. This plan contains costs and schedules for the work required to ready the facilities and prepare documentation. Although receipt date of the TMI-2 core samples is presently uncertain, it is assumed for readiness purposes that the first core canisters will arrive by commercial carrier during the last quarter of FY-84.

The primary facilities selected for use in the Core Activities Program and the operations they will perform are as follows:

- TAN-607 Hot Shop -- Fuel receiving and transfer
- TAN-607 Hot Cell -- Fuel examination preparation
- TAN-607 Storage Pool -- Fuel storage
- TRA Hot Cell, ARA Hot Cell, Hot Fuel Examination Facility, CPP Remote Analytical Facility. -- Fuel examination

Although other facilities at INEL have similar capabilities, TAN-607 was selected to perform the first three operations because the other facilities are presently committed and will not be available for full-time dedication to the TMI Program. However, these facilities could provide strong backup to TAN-607 during an emergency. Personnel at these other facilities feel they could perform part or all of the examination tasks if need be without impacting other programs, by scheduling TMI examinations with existing work. Since fuel-examination requirements are not yet firm, facilities were not identified for specific tasks. This report describes each facility and lists examination capabilities.

Documentation needed to be complete prior to receipt of the first core samples is identified for TAN-607 in areas of safety, environmental protection, safeguards and security, quality assurance, and operations. This type of documentation for the other examination facilities should already exist, be relatively easy to update, and would not be a critical-path item. These facilities routinely receive shipments of irradiated fuel samples for examination, and the TMI samples would, in all probability, be within the sphere of work of previously analyzed accidents.

Of primary concern in the documentation area is the input data needed to start work on some of the documents. The safety and environmental documents, for instance, need data on the characterization of the fuel debris to be shipped, as well as on the characterization of the shipping container. Without these data, completion of several important documents could be

delayed. Interfaces and lead times for all documents are shown on the schedule of the preliminary project plan.

Review of INEL casks and transportation equipment show that samples for examination can be moved between existing INEL facilities with few problems. Moving the proposed 14-ft shipping canister between facilities, however, is cited as a possible problem. Presently, it is planned to open the canisters at TAN-607 and to ship only small samples to the examination facilities. Shipping a 14-ft canister to the only other facility capable of handling it, the Hot Fuel Examination Facility (HFEF), would require adaption of one on-site cask.

The preliminary project plan contains costs and schedules for all items needed to start receipt of the core canisters by the fourth quarter of FY-84. These include facility modifications, documentation, and first-year trade-off studies. The schedule shows that no insolvable problem exists in completing all necessary work before late FY-84, assuming that the data needed for specific items will be received on schedule.

Appendixes to this report describe in more detail the WBS tasks and facility modifications discussed in the body of the report.

ACKNOWLEDGMENTS

The input from various INEL organizations is acknowledged in the preparation of this report. L. S. Richardson, C. K. Mullen, D. M. Mandiloff, and J. A. Cook from EG&G Hot Cells Branch provided input on the conditions and capabilities of those facilities. D. P. Frank from EG&G Facilities Management provided information on the conditions and modifications planned for the facilities under study. J. P. Bacca and R. D. Phipps supplied information on the capabilities of the Argonne National Laboratory facilities at INEL. L. W. McClure, L. C. Lewis, and W. A. Emel, Exxon Nuclear, provided data on the capabilities of the Idaho Chemical Processing Plant Facilities.

CONTENTS

ABSTRACT	11
SUMMARY	11i
ACKNOWLEDGMENTS	vi
1. INTRODUCTION	1
2. FACILITY DESCRIPTIONS	4
2.1 Receiving and Transfer Facility	4
2.2 Preparation Facility	11
2.3 Storage Facility	16
2.4 Examination Facility	20
2.4.1 General	20
2.4.2 Auxiliary Reactor Area (ARA) Hot Cells	20
2.4.3 Test Reactor Area (TRA) Hot Cells	23
2.4.4 Hot Fuel Examination Facility (HFEF)--North and South	26
2.4.5 Idaho Chemical Processing Plant (ICPP)	33
3. ADMINISTRATIVE	38
3.1 Environmental	38
3.2 Safety	40
3.2.1 Documentation	40
3.2.2 Reviews	42
3.2.3 Training	43
3.3 Safeguards and Security	43
3.4 Quality Assurance (QA)	44
3.5 Operations	45
4. TRANSPORTATION AND CASKS	46
4.1 Casks	46
4.2 Railroad Facilities	48
4.3 Roads and Bridges	48

5.	PROJECT PLAN, COSTS, AND SCHEDULES	49
5.1	INEL Facility Readiness Project Plan	49
5.1.1	Project Objectives	50
5.1.2	Work Plan	50
5.1.3	Project Definition	51
5.1.4	Schedule	51
5.1.5	Costs	55
6.	REFERENCES	56
	APPENDIX A--TMI-2 CORE CHARACTERISTICS	A-1
	APPENDIX B--RADIATION FIELD FROM 250 TMI FUEL ASSEMBLIES IN CANAL	B-1
	APPENDIX C--WORK BREAKDOWN STRUCTURE DICTIONARY	C-1
	APPENDIX D--DESCRIPTION OF FACILITY MODIFICATIONS	D-1

FIGURES

1.	Locations of facilities at INEL	3
2.	TAN-607 building showing Hot Shop, Hot Cell (RML), and storage pool	5
3.	Plan view of TAN-607 Hot Shop	6
4.	Elevation view of Hot Shop remote handling equipment	6
5.	Elevation of HFEF-N showing the cask transfer tunnel and neutron radiography facility	8
6.	Plan view of FAST Fuel Storage Area (FSA)	10
7.	Plan view of the Irradiated Fuel Storage Facility (IFSF)	12
8.	Plan view of TAN-607 hot cell (RML)	14
9.	Elevation view of TAN-607 (RML) hot cell showing handling equipment	15
10.	Elevation view of TAN-607 storage pool	18
11.	Plan view of ARA hot cells	21

12. Plan view of TKA hot cells	24
13. Plan view of HFEF-N	27
14. Elevation view of HFEF-N	28
15. Plan view of HFEF-S	31
16. Elevation view of HFEF-S	32
17. Plan view of the Remote Analytical Facility	34
18. Plan view of the Remote Analytical Laboratory	37
19. TMI-2 Core Examination Program's INEL facility readiness plan work breakdown structure	52
20. INEL facility readiness project schedule	53
B-1. Radiation field at a point 1 ft above the water surface	B-4

TMI-2 CORE EXAMINATION PROGRAM:
INEL FACILITIES READINESS STUDY

1. INTRODUCTION

In order to acquire and preserve data from the damaged TMI-2 reactor core, the entire core debris will be shipped to the Idaho National Engineering Laboratory (INEL) for examination and storage as part of a TMI-2 Core Examination Program. The objectives of this examination and these analyses are to provide the analytical data necessary for understanding the accident sequence that occurred in the TMI-2 reactor, and to provide a data base for predicting and controlling nuclear fuel behavior during degraded-core-cooling situations.

A study was undertaken to review the status and capabilities of INEL facilities that might be used in the TMI-2 Core Examination Program. This study considered all activities to be performed during the course of the core examination and evaluated the adequacy of INEL facilities. Activities considered were cask receiving, material handling, storage, decontamination, examination, material shipment to other laboratories, and waste disposal. In addition, a review of the administrative requirements that must be ready before the core arrives was done at the same time.

The products of this study are (a) a document describing the capabilities of the INEL facilities, (b) a plan defining the work needed to ensure that the INEL is ready for the Core Examination Program, and (c) guidance about the budget expenditure necessary for facility and administrative preparations. The description of the INEL facilities, the definition of administrative documentation, and the program plan are contained in the following sections of this report. Section 2 contains a description of those facilities selected to perform specific functions of the examination program. Section 3 discusses the administrative documentation identified as necessary for the proposed program. Section 4 describes the transportation and cask facilities available for movement of core samples within the INEL boundaries. Section 5 contains the preliminary plan, costs, schedule,

and definition of the work needed to prepare the INEL for the Core Examination Program. Specific technical issues are also discussed in Section 5. The locations of the facilities discussed in this report are shown in Figure 1. The parameters and requirements against which the site capabilities were evaluated are contained in Appendix A.

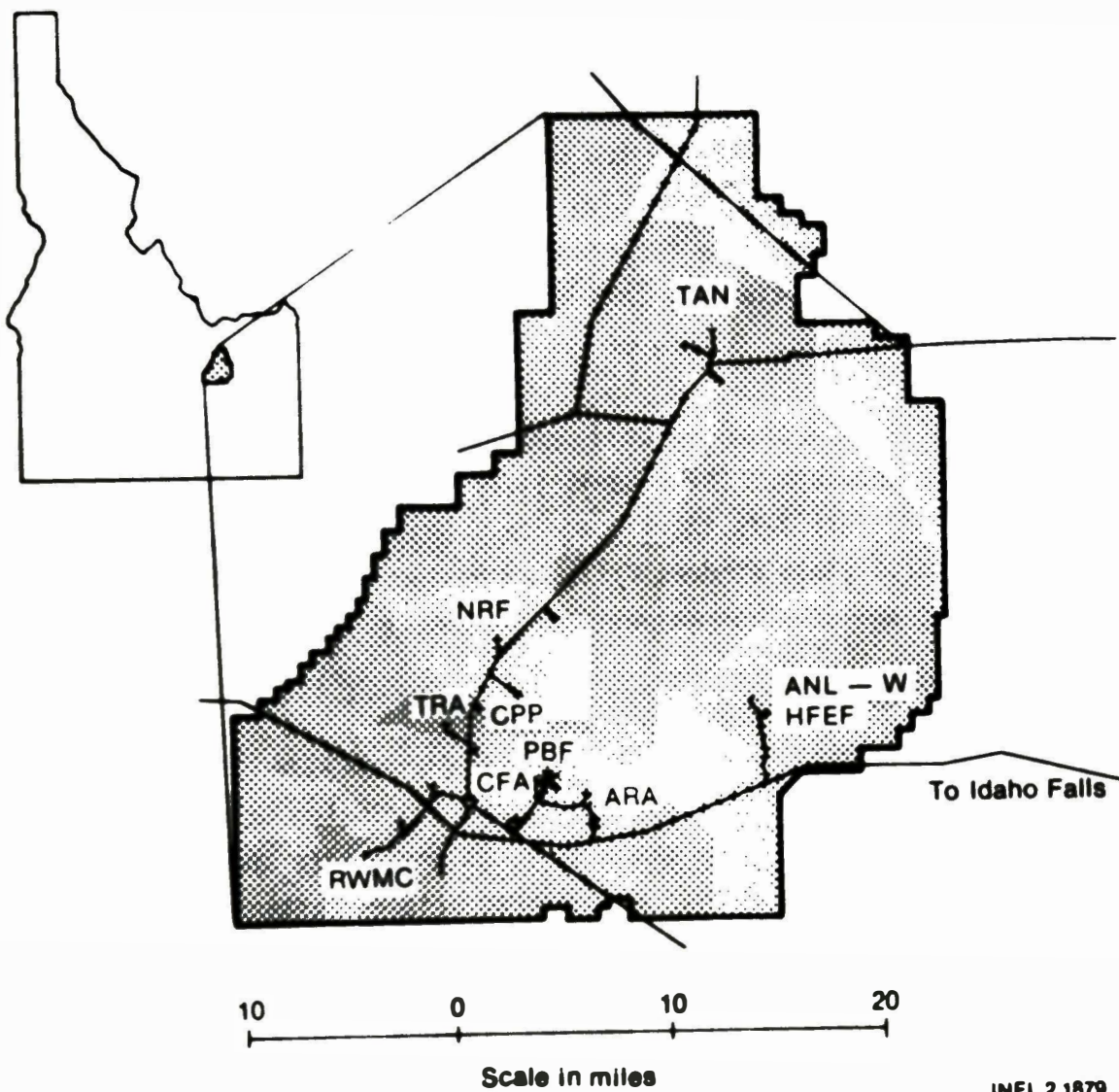

INEL 2 1879

Figure 1. Locations of facilities at INEL.

2. FACILITY DESCRIPTIONS

2.1 Receiving and Transfer Facility

The receiving and transfer facility is to be used for receipt of the commercial shipping cask, unloading the fuel canister, and transfer of the canister either to storage or to a preparation area for further work. The major requirements for this facility are that it be capable of receiving a truck with cask, of handling a commercial cask, and that it have a shielding and/or remote handling capability for unloading the canister from the cask. The principal facility selected for this operation is the Test Area North (TAN) 607 Building Hot Shop. A view of the Hot Shop is shown in Figure 2.

The TAN Hot Shop is a shielded cell designed for remote handling of large radioactive components. The shop is 51 ft wide by 160 ft long by 55 ft high. The walls are 7-ft thick concrete. Shielded viewing is provided by 6-ft thick glass windows filled with zinc bromide. The location of the windows and of other major items in the Hot Shop is shown in Figure 3.

The Hot Shop is served by a variety of remotely-operated handling equipment. The largest piece of equipment is the 100/10-ton bridge crane for moving heavy assemblies. This crane services the entire shop and can lift an emergency load of 150 tons. An overhead bridge-mounted electro-mechanical manipulator (U-Man) can also service the entire shop. The manipulator can lift a 600-lb load with its fingers and has a shoulder hook capable of supporting loads of up to 5000 lb. Three wall-mounted manipulators are installed for light duty work. These manipulators can travel both horizontally and vertically along the Hot Shop walls and have jib booms that can be swung from the wall to the center of the shop. Two manipulators are installed on the south wall and one on the north wall. Figure 4 is an elevation view showing the equipment discussed above. Window G, at the northwest corner of the Hot Shop, contains heavy duty master-slave manipulators that can be used to work on objects at that window.

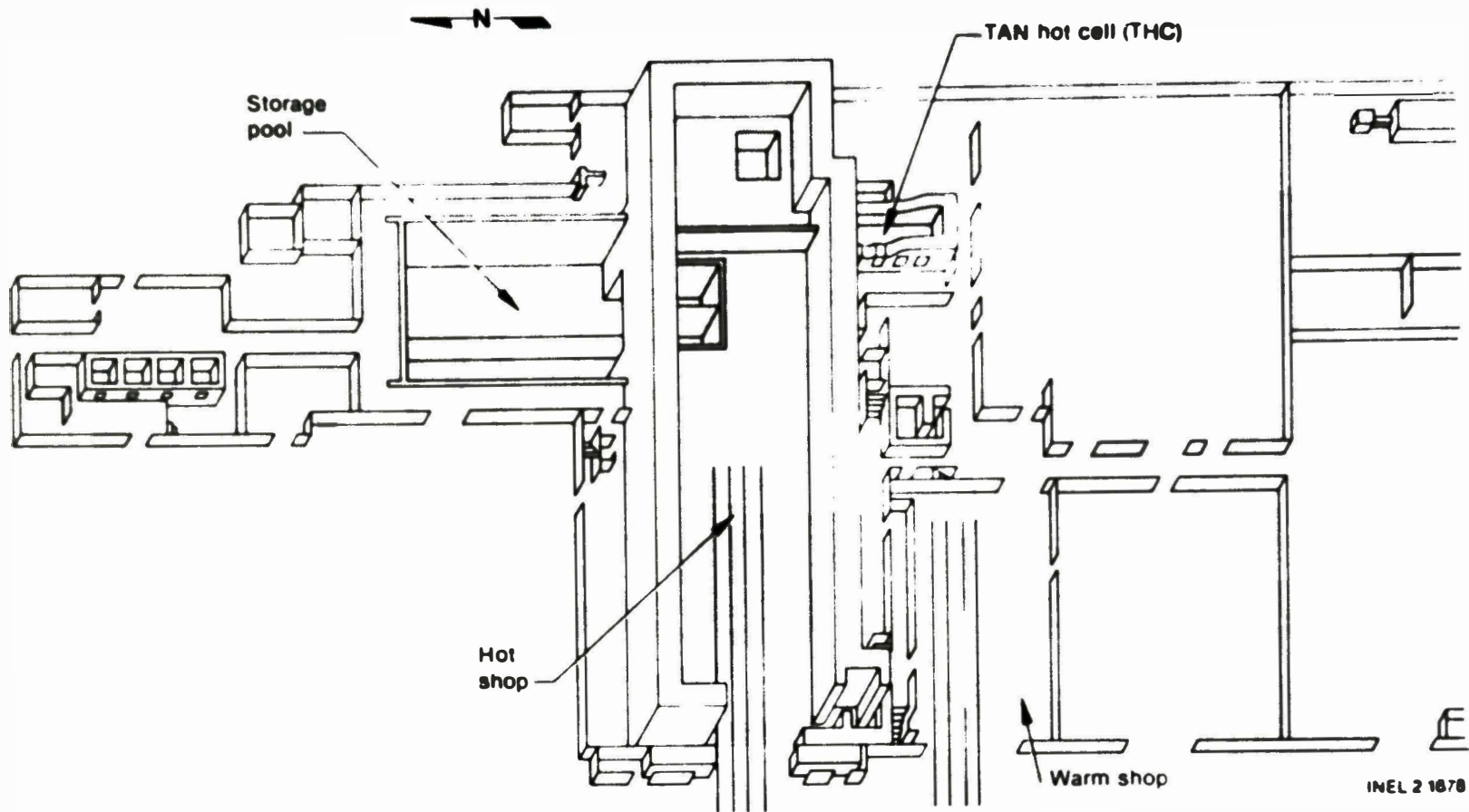

Figure 2. TAN-6U7 building showing the TAN Hot Shop, Hot Cell (THC), and storage pool.

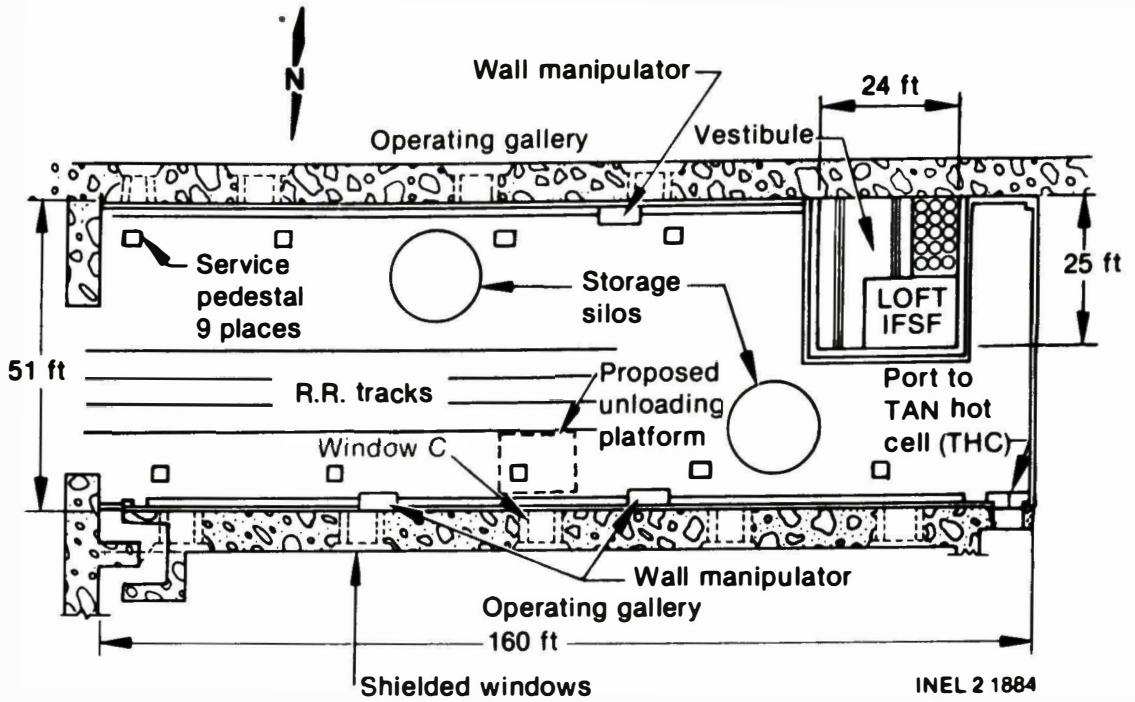

Figure 3. Plan view of TAN-607 Hot Shop.

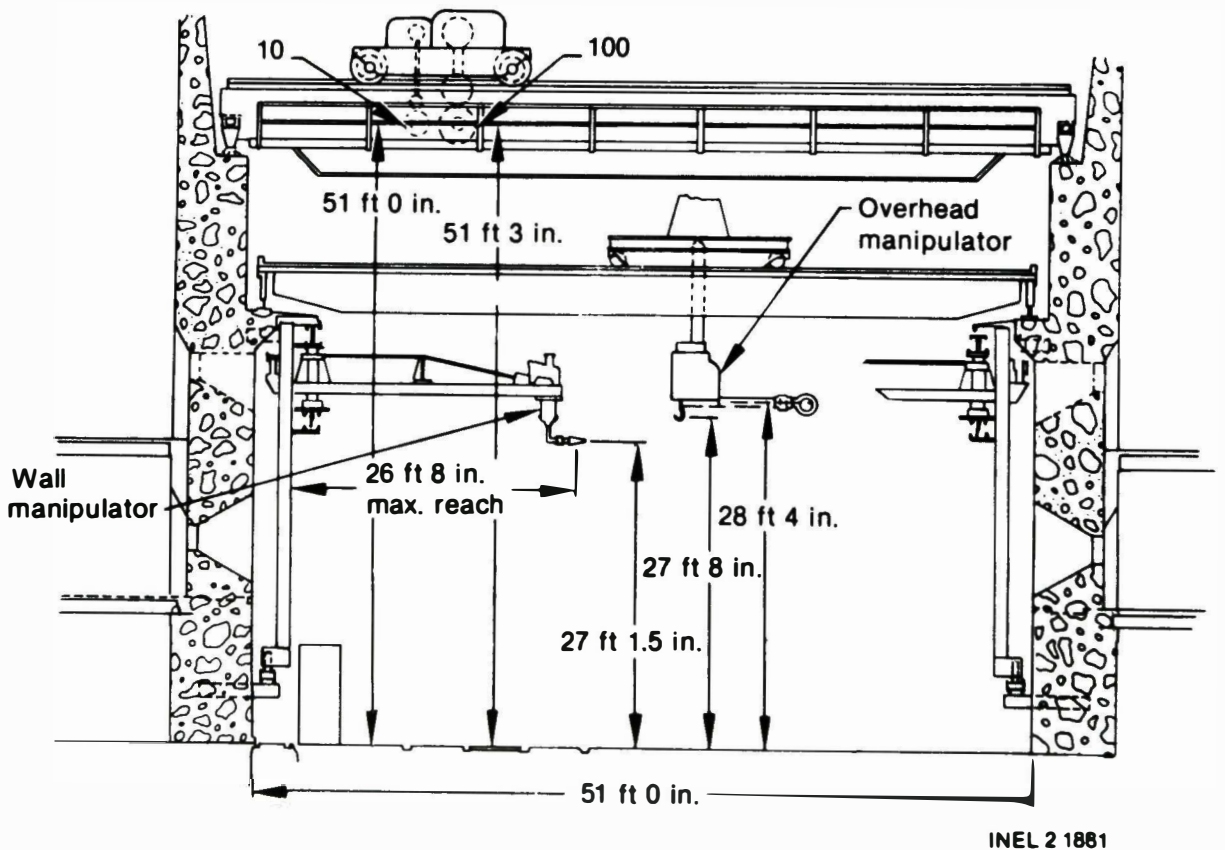

Figure 4. Elevation view of Hot Shop remote handling equipment.

The Hot Shop contains a main door on its west end, capable of allowing heavy equipment to enter the facility. The allowable floor loading for the shop is 250 lb/ft², but heavy concentrated loads can be located within the Hot Shop by positioning them over specific support areas.

The handling equipment described above is capable of performing all receiving and transfer operations envisioned for the TMI-2 Core Examination Program. The 25-ton or even 70-ton casks, considered as possible shipping casks for the core samples, can be lifted and off-loaded in the Hot Shop using the 100-ton crane. Either the 10-ton bridge crane or the O-Man can remotely lift and move a fuel canister to the storage pool or to the preparation area, which will be the TAN Hot Cell (THC) at the east end of the shop. The THC was previously known as the TAN Radioactive Materials Laboratory (RML). Decontamination operations can be performed within the Hot Shop on the cask or transporter, if required.

The seismic rating for the TAN-607 building conforms to the Uniform Building Code (UBC), Zone 2. The general condition of the Hot Shop is rated as good, although there are upgrades required to bring it to full capacity. These upgrades are outlined in Section 5 of this report.

Several other INEL facilities were considered for the receiving and transfer operations. These were the Hot Fuel Examination Facility-North (HFEF-N) and the Idaho Chemical Processing Plant (ICPP). The HFEF-N has all the capabilities to handle a cask weighing up to 50 tons, remotely handle a canister, and temporarily store the canister. Since the facility was not specifically designed to handle commercial casks, the ability to transfer a canister from a cask is uncertain. The cask-transfer tunnel, Figure 5, is not high or wide enough to handle a top-loading commercial cask. The high bay above the cells can accommodate only bottom-loading casks. While these problems could be overcome by facility modifications or by special casks, the present and projected work load for the HFEF may not lend itself to absorbing the dedicated schedule necessary for the TMI work. The facility personnel are presently supporting the Liquid Metals Fast Breeder Reactor (LMFBK) Program, which is their first priority.

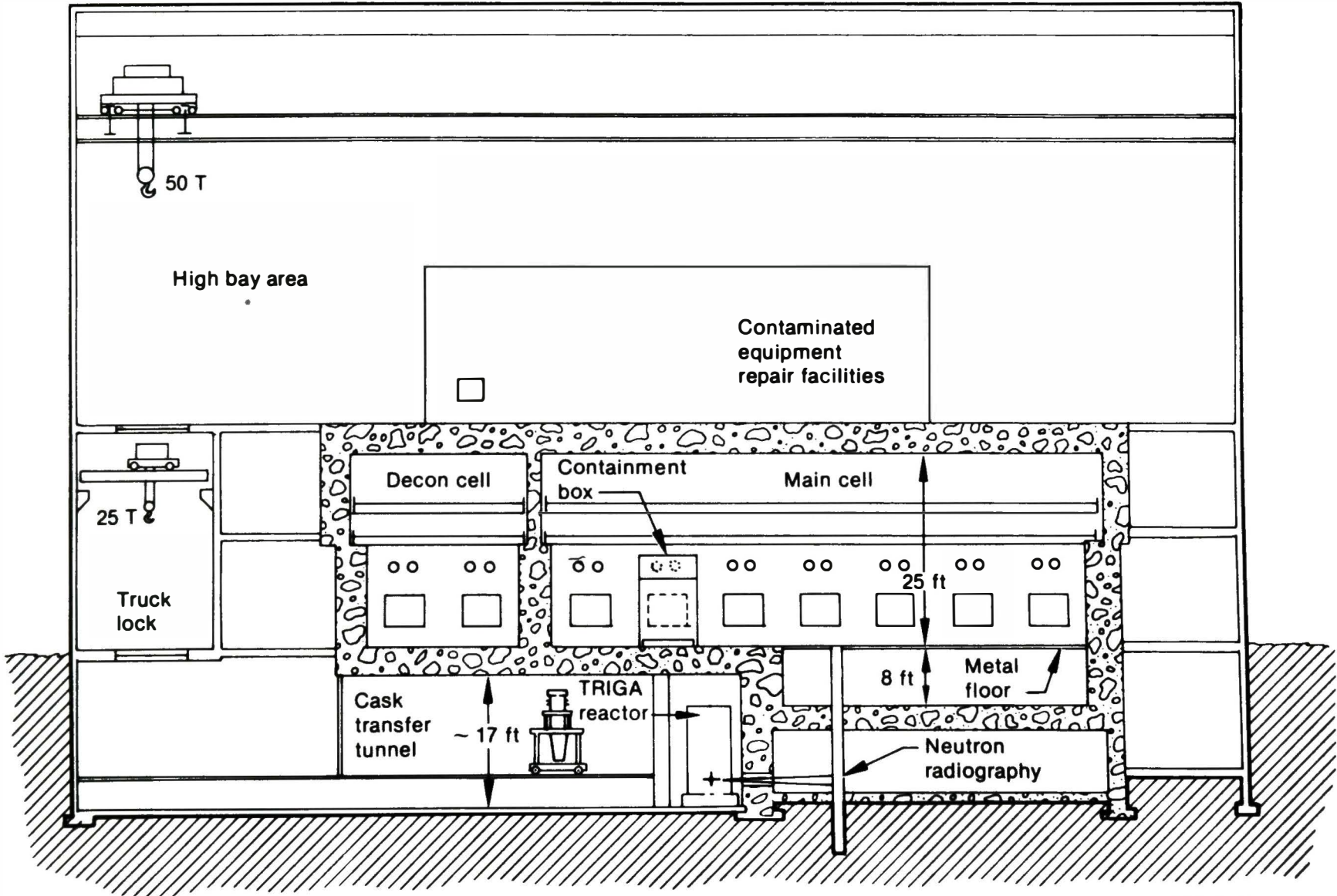

INEL 2 1885

Figure 5. Elevation view of HFEF-N showing the cask transfer tunnel and neutron radiography facility.

ICPP has two facilities capable of receiving and transferring a canister to a shielded area. These are the Flourinel and Storage (FAST) Facility and the Irradiated Fuel Storage Facility (IFSF). The FAST Facility is presently under construction, but the Fuel Storage Area (FSA) of the facility will be available for operation in April 1984. The FAST FSA receiving capabilities are divided into four areas as shown in Figure 6. These consist of the truck and railcar receiving bay, the cask receiving and decontamination area, a fuel storage area, and a fuel-cutting facility. The receiving bay serves as an airlock where trucks and railcars can enter the FAST Facility, thus minimizing the effects of outside weather conditions on the main facility. The inner and outer doors are interlocked so that neither may be opened until the other is closed. This bay has equipment for washing road dirt from casks and vehicles; it is large enough to accommodate two transports side by side.

The cask receiving and decontamination area is used for radiation surveys, decontamination of casks, trucks and railcars, as well as loading or unloading casks on trucks or railcars. The area can house two transports side by side. An overhead 130-ton crane with a 25-ton auxiliary hoist are used for unloading casks. There is a cask storage area and two decontamination rooms equipped with water, steam, chemical sprayers and cask venting systems. The entire receiving area can adequately handle commercial fuel shipping casks, if necessary.

After the canisters have been unloaded from their casks and decontaminated, they can be moved to an adjacent fuel-storage area (as shown in Figure 6) where they are lowered into one of two cask unloading pools. The pools are 31 and 41 ft deep respectively, which enables personnel to remove the cask contents underwater with adequate shielding. Two 10-ton cranes are provided for unloading the cask contents and transferring those contents to the isolation, storage, or cutting pools. The isolation pools are connected to the unloading pools for the inspection and canning of fuel, when required. The unloading pools also connect with a transfer canal where the cask contents can be moved underwater, using the 10-ton cranes, to a storage area.

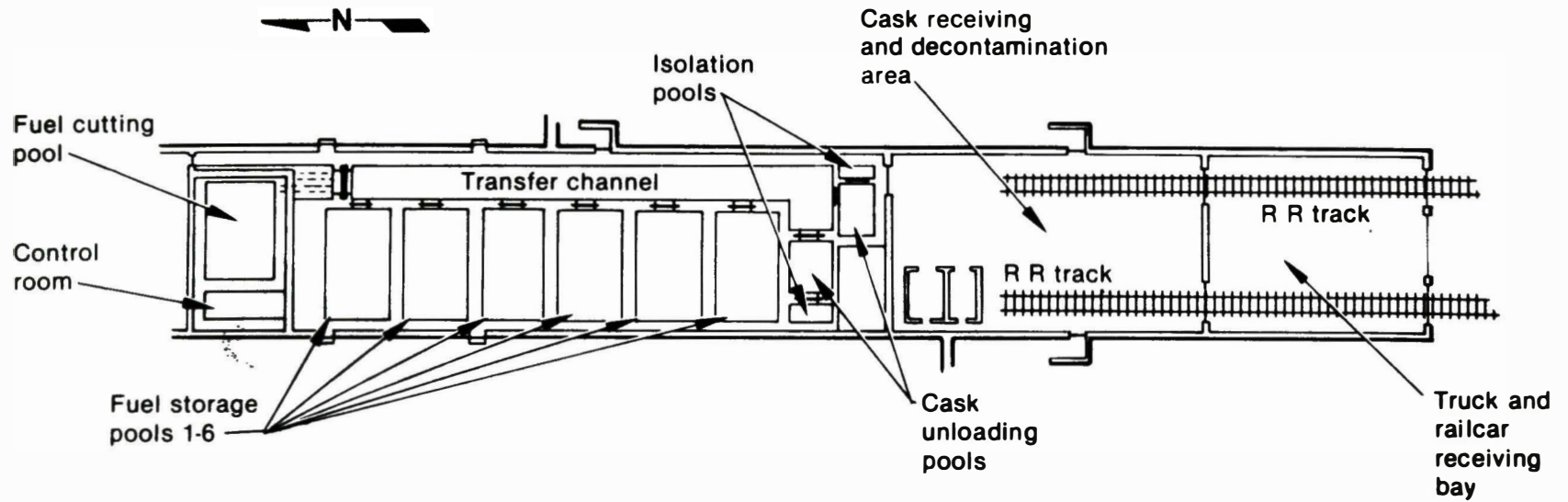

INEL 2 1999

Figure 6. Plan view of FAST Fuel Storage Area (FSA).

The IFSF is used for the receipt, unloading, and storage of irradiated fuel. Unlike the FAST Facility, all operations performed at the IFSF are in an air environment. The facility is divided into several functional areas as shown on Figure 7. The cask-receiving area is capable of receiving truck or railcar cask shipments. It is equipped with 75- and 15-ton cranes for unloading and handling casks. The casks are placed in the transfer pit where their contents can be removed. A specially-designed transfer car is used to move the cask from the transfer pit to the fuel-handling cave. The car is designed in such a way that the fuel-handling cave is always isolated from the cask-transfer pit even when the car is in motion.

The fuel-handling cave is equipped with a 10-ton bridge crane and a bridge-mounted electromechanical manipulator with a 1000-lb capacity shoulder hook, 2-ton hoist, and a hand with 300 lb capacity. The cave is used for transferring fuel from shipping casks and preparing fuel for storage. Temporary storage wells are contained in the floor of the cave to accept shipping baskets and containers. Only two of the wells are capable of accepting the TMI-2 core canisters.

The FAST Facility and IFSF both have the capability to receive the TMI-2 core-fuel shipments and transfer the fuel from the casks into a shielded area. The IFSF is limited to storing two canisters, but the FAST Facility has large storage areas. Both facilities, however, are committed for other programs and would not be available to supply dedicated support to the TMI Program. If it is necessary to have an emergency backup facility for TAN-6U7 operations, further discussion with FAST Facility personnel will be necessary. Questions of use and funding need to be resolved. The extent of possible use as well as the impact on the existing programs need determination. Funding will have to be provided to prepare procedures, train personnel, make a safety analysis, and procure equipment.

2.2 Preparation Facility

Prior to examination of any core samples, the shipping canisters must be moved to a preparation facility. This facility must have the equipment

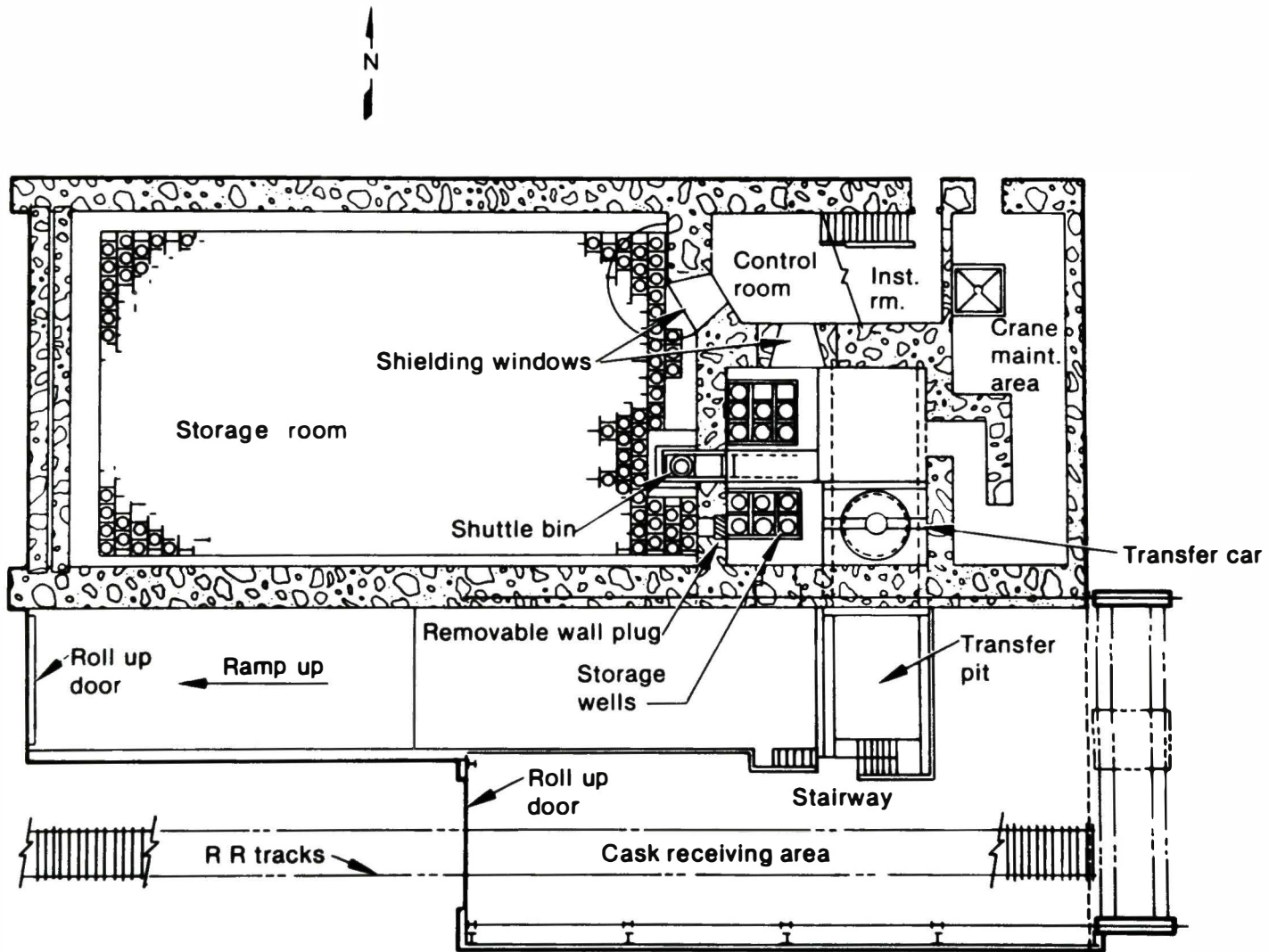

INEL 2 2000

Figure 7. Plan view of the Irradiated Fuel Storage Facility (IFSF).

and personnel necessary to open the canisters (which are to go directly to storage), remove the contents, and repackage samples for shipment to other INEL facilities, national laboratories or commercial facilities. Opening the canisters to make an inventory or inspection of their contents could also be required. For these purposes, a facility must be available that has the remote handling and shielding capability for handling a 14-ft long canister. The facility selected for this task is the TAN Hot Cell (THC).

The TAN Hot Cell adjoins the southeast end of the main TAN Hot Shop as shown in Figure 2. The THC was designed for the observation, handling, and examination of small radioactive objects. It is 35 ft long by 10 ft wide and has access to the Hot Shop through a door at the north end of the cell (see Figure 8). Four viewing windows, each equipped with master-slave manipulators, make it possible for personnel to do hot cell work from an operating gallery. Two overhead bridge-mounted manipulators serve the entire THC. These manipulators have a 150-lb hand capacity, 750-lb capacity shoulder hooks, and 2-ton chain hoists. Figure 9 is an elevation view of the THC showing the windows and manipulators.

The access door from the THC to the Hot Shop is equipped with an air pallet with 2-ton capacity and enters the THC through two sliding shielding doors 46 in. wide by 8 ft high. The air pallet is stored on the Hot Shop side of the door. The false floor inside the THC on which the air pallet rests is capable of sustaining a 2-ton load.

The THC is constructed so that the TMI fuel canisters could be handled in a horizontal position when their contents are extracted. There is sufficient room within the THC to install any welding, cutting, or other equipment to open or close the canisters. The THC contains roughing filters, HEPA filters, and halogen absorbers.

Mounting, grinding, polishing, and photomicrography of fuel samples has been done in the past at the THC, but equipment does not presently exist to perform these operations. This work is normally done for small samples at the Test Reactor Area (TRA) hot cell, which is described in Section 2.4.3. Samples can be transported from the THC to TRA in existing

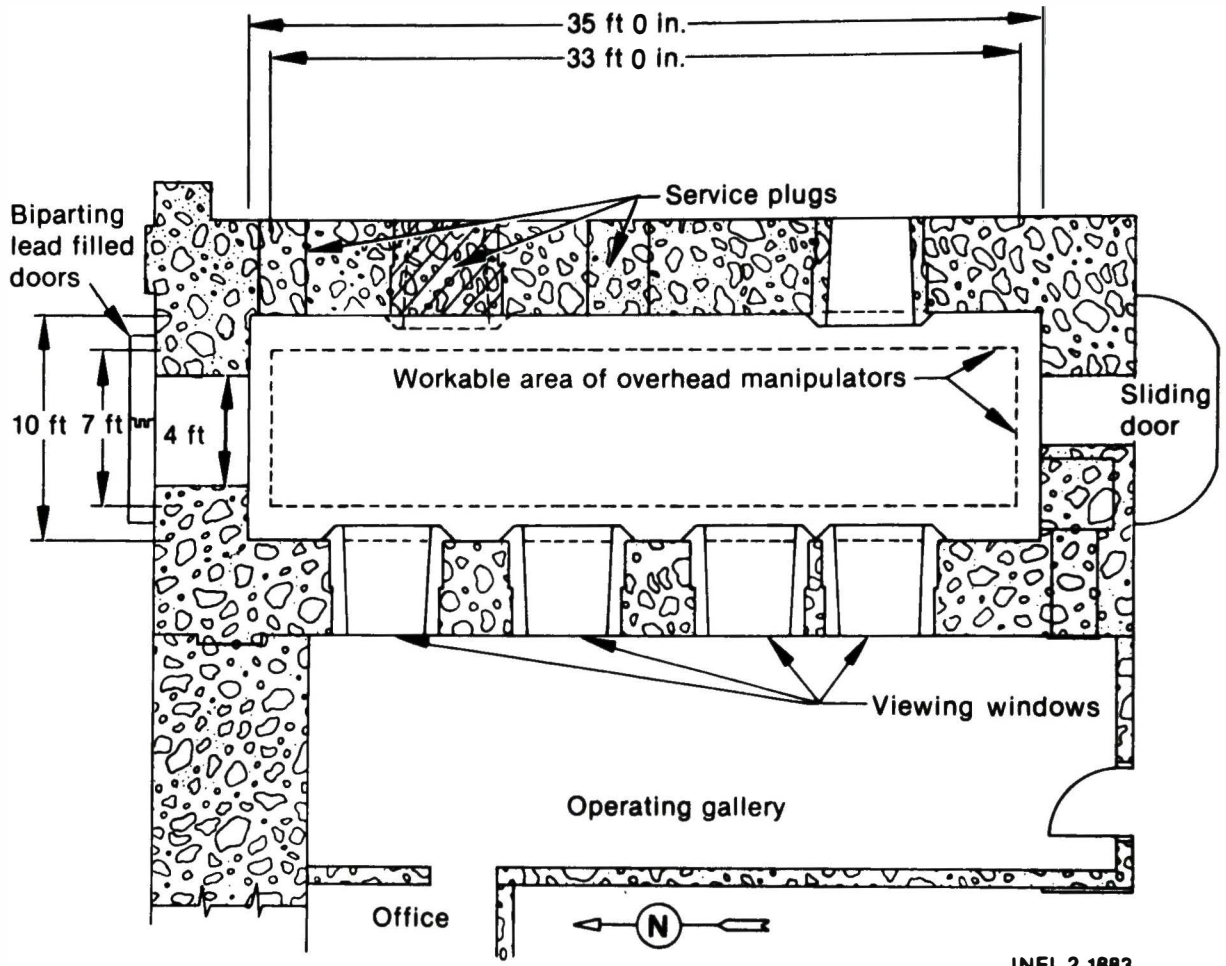

INEL 2 1883

Figure 8. Plan view of TAN-607 Hot Cell (THC).

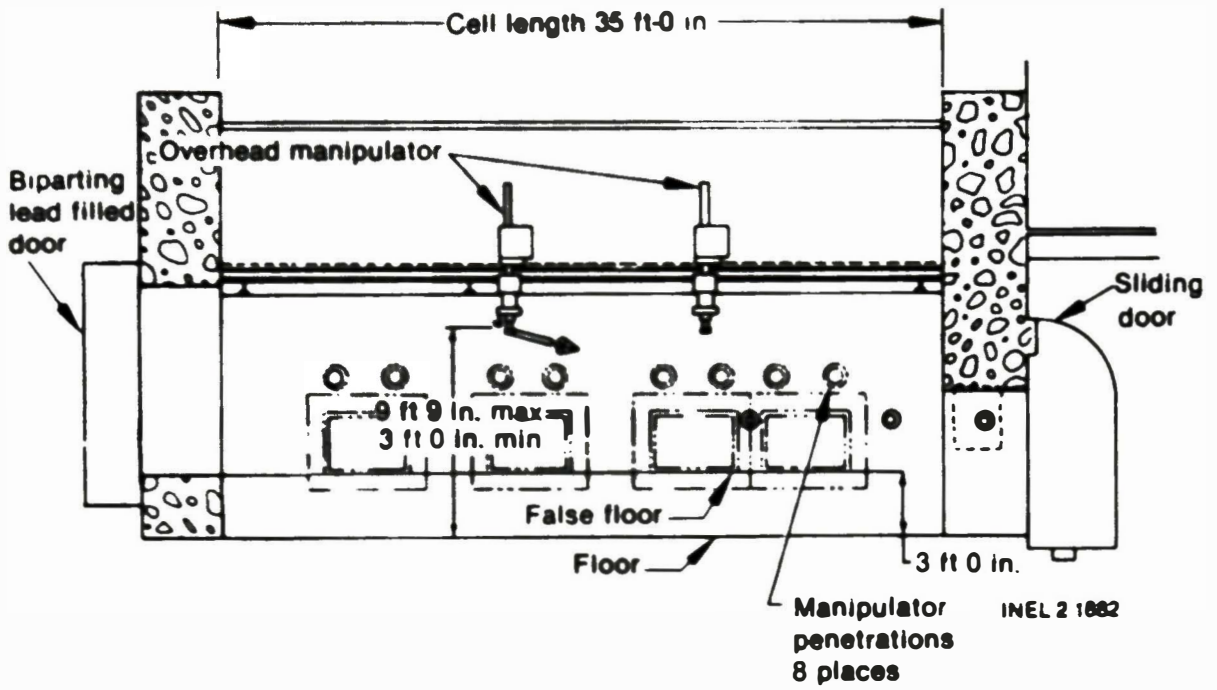

Figure 9. Elevation view of TAN-607 Hot Cell showing handling equipment.

INEL casks. The THC is equipped to handle the canisters, open them, transfer samples to smaller canisters for shipment to other sites, and reclose the canisters. Proposed polishing and grinding equipment would allow THC personnel to prepare large samples for metallographic examination. The THC is seismic rated for UBC Zone 2, and its general condition is good. Some upgrades have been identified for specific items, which are outlined in Section 5.

Other facilities were considered to perform the preparation operations. The most promising of these facilities was HFEF-N. The facility was discussed in Section 2.1. as a possible receiving facility. The HFEF-N contains all necessary equipment to perform any of the preparation operations including mounting, grinding, and polishing of samples. It is an alpha-qualified facility. However, the TAN-607 Hot Cell was selected because it allows the canister to remain in a single facility after it is received. Also, there are the previously discussed problems of transferring a canister to HFEF-N from a commercial cask, and HFEF's present dedication to the LMFBR Program. The HFEF-N facility could be an alternate location for the preparation of TMI fuel as long as this preparation does not interfere with other work, and if prior arrangements have been made for them to receive the fuel. The canisters could be transferred in the TAN-607 Hot Shop to a cask that would be compatible with the HFEF-N receiving equipment.

The FAST Facility and IFSF are both designed to prepare fuel for storage or processing, but neither facility presently contains the equipment required to open canisters and cut fuel element structural members. They were not considered further for this task.

2.3 Storage Facility

The storage facility is intended to store the entire TMI-2 core in canisters, from which samples for examination will be taken. The major requirements of this facility are that it be capable of handling a fuel canister, provide shielding to personnel, and store the fuel in a non-critical configuration. It is estimated that storage will be needed for

as many as 250 canisters, which will contain the entire TMI-2 core. Although dry storage was considered, wet storage was selected for economy. The TAN-607 storage pool was selected for storing the core canisters. The pool will adequately store the entire TMI-2 core and is accessible to the recommended receiving and transfer, and preparation facilities.

The TAN-607 storage pool adjoins the northeast end of the TAN Hot Shop, Figure 2. There is a pool vestibule in the Hot Shop where canisters can be lowered onto a cart located on rails at the bottom of the pool. Access to the main pool is gained by pulling the cart from the vestibule to the main pool with a power winch.

The vestibule pool is 24 ft wide by 25 ft long. The storage pool is 48 ft wide by 70 ft long. The entire pool is 24 ft deep. A shielding wall 6 ft 10 in. thick between the hot shop and storage pool area extends 5 ft down into the pool, providing an air-tight seal between the two areas. An elevation view of the pool is shown in Figure 10. The storage pool is served by a 15-ton bridge crane, mounted on a working bridge over the pool. Although LUFT-IFSF is using part of the pool, it will not interfere in any way with the TMI-2 Core Examination Program.

With installation of modular storage racks, the pool can easily accommodate the examination-sample canisters in either vertical or horizontal storage positions. Preliminary calculations (Appendix B) show that 10 ft of water is more than adequate to shield the canisters. If the rails for the cart remain free and if all canisters are stored within the operating limits of the 15-ton crane, there is sufficient space to store the entire core. This assumes canisters are stored on 2-ft centers in either the horizontal or vertical position. Neither position is ideal. Horizontal storage makes it necessary to move the top store racks to get at the lower ones. Vertical storage requires that modularized storage racks be moved between other racks to keep them below the water.

Another possible problem with using the pool to store the entire core for long periods is the thermal effect of the fuel decay heat on the water temperature. The pool presently has no cooling system except natural

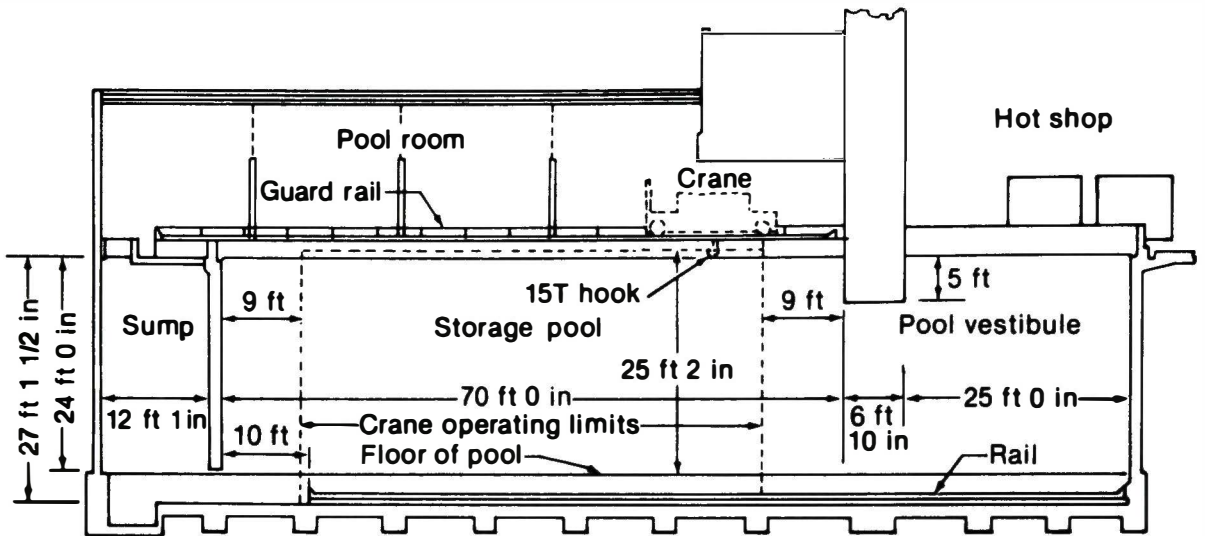

INEL 2 1876

Figure 10. Elevation view of TAN-607 storage pool.

convection to remove heat. Temperature increases of the pool water may enhance algae growth and complicate keeping the pool water clean.

The examination samples, and archive fuel (fuel not to be examined in this program), should be stored in a readily accessible area. The storage pool is logical for the archive fuel, and there should be no problem in using the pool for interim storage of the examination-sample canisters. Heat generation will be minimal, and there is sufficient space to store vertically or horizontally, with little concern about criticality.

Several other INEL facilities were considered for the fuel storage. These were HFEF-South, the FAST Facility, CPP/IFSF, and the Engineering Test Reactor (ETR) canal. HFEF-S is presently slated for fuel storage in support of HFEF-N operations. But in-cell space is available for other storage or use. The major problem is that unloading a commercial cask with a 14-ft fuel canister would require facility modification.

The FAST Facility is fully capable of storing the fuel canisters in two of its six storage pools (see Figure 6). The storage pools are equipped with two 10-ton cranes capable of removing the canisters from the unloading pool area and depositing them in the first two of the storage pools via the transfer channel. These pools are 41 ft deep; the other four are 31 ft deep. The storage pools have ultraviolet and chiller systems to control algae growth and maintain the water temperature within specified limits. Each storage pool has a minimum floor area of 1440 ft². Storage in the cutting pool may be preferred since it has a special H&V system and because it can be totally isolated from the rest of FSA. However, the FAST FSA is committed to other programs and cannot be used for storing all the TMI fuel. Special arrangements would have to be made in advance even for emergency storage of small amounts of TMI fuel. Moreover, special racks to hold the canisters would be needed.

The CPP/IFSF was considered for storage but was not found acceptable. The shuttle bin for moving fuel from the handling cave to the storage area can only accommodate 13-ft canisters. In addition, all storage space in the facility is committed to other programs.

A review of the ETR facility was undertaken because it is presently being shut down. The facility contains a T-shaped canal that could be used for fuel storage. But the canal is only 20 ft deep, limiting the storage method to horizontal placement of the canisters. The 50-ton crane is available, but no equipment exists for shielding during unloading of a canister from a cask. Also, the facility is not considered suitable for storage since the canal-floor space available for storing the entire core is marginal; furthermore, it has no advantage over the TAN storage pool for storing examination samples. The facility will be shut down, with all systems deactivated. To use the canal would require reactivation of these systems as well as opening and manning a large facility for use of a small storage space. The only advantage appears to be that the facility is rated higher by seismic criteria than TAN-607.

2.4 Examination Facilities

2.4.1 General

The criteria for examination of the fuel samples have not been firmly established at this time. Therefore, no facility was selected to perform the examination of fuel samples. It is very likely that no single facility will be used for examination; rather, several will be used, depending on their particular capabilities. This section describes all of the INEL examination facilities and lists capabilities for each.

2.4.2 Auxiliary Reactor Area (ARA) Hot Cells

The ARA hot cells consist of two adjoining shielded cells in Building 626 of ARA No. 1. Figure 11 shows a plan view of these cells. Cell No. 1 has two work stations, with master-slave manipulators. The cell has a floor area 8 by 16 ft and a ceiling height of 14 ft. An overhead bridge-mounted electromechanical manipulator serves the entire cell with a hand and shoulder hook capable of lifting 750 lb. An overhead hoist capable of lifting 2 tons is also installed in the cell.

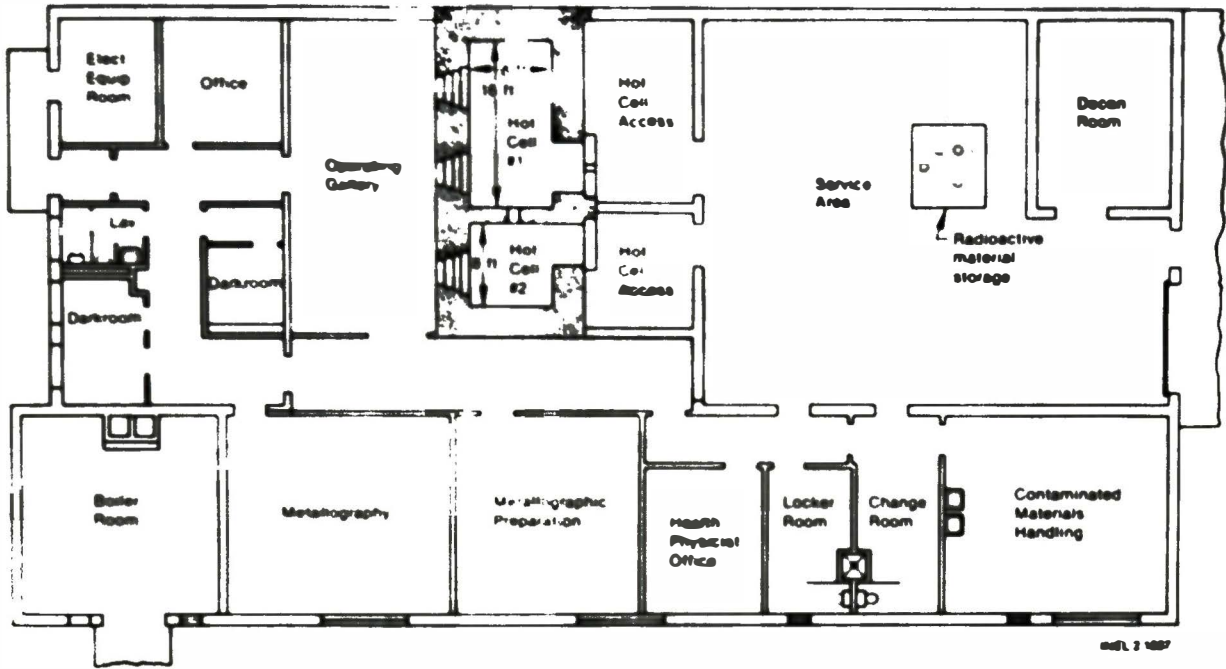

Figure 11. Plan view of ARA hot cells.

Cell 2 has a single work station, with manual manipulators. The cell has a floor area 8 by 8 ft and a ceiling height of 14 ft. An overhead hoist, capable of lifting 1 ton, is installed in the cell. A port capable of passing small samples and tools connects the two cells.

The cells have an air atmosphere, off-gas being passed through HEPA and charcoal filters. Shielding consists of 36 in. of high density concrete. The cells are limited to handling experiments no larger than 9 in. outside diameter by 8 ft long, and a maximum weight of 750 lb. The cell's primary uses are to mechanically dismantle experimental fuel assemblies, perform preliminary encapsulation of specimens for further examination, and to perform initial examinations of the specimens. Machine tools, welding and cutting equipment, and a 50-joule pulsed laser are available to the cells. Work is normally performed in the horizontal position.

Examination capabilities of the cell are listed below:

- Photography through cell windows
- Photography through either of two periscopes
- Particle size determination by screen separation
- Weighing (5×10^{-5} to 3×10^3 g)
- Density determination by immersion
- Furnace heating in an air atmosphere.

Supporting the cells are a decontamination room, an equipment storage and mockup (service) area, a darkroom, and a contaminated materials handling area. Liquid radioactive wastes are routed to a storage tank for final disposal at the ICPP; solid wastes are shipped to the Radioactive Waste Management Complex (RWMC). The cells are in good condition.

2.4.3 Test Reactor Area (TRA) Hot Cells

The TRA hot cells consist of three separate shielded cells in Building 632 of TRA. The cells have been dedicated to the examination of light water reactor fuels. Figure 12 shows a plan view of the hot cell area. Cell 1, with dimensions of 7 by 14 by 14 ft high, has three work stations. Included within the cell is a 4- by 8- by 6-ft high isolation enclosure utilizing the center and west windows. The isolation enclosure has three master-slave manipulators penetrations; the remaining cell work station has two manipulators. The cell has been used primarily for fuel rod and sample cutting, encapsulation, and particle-size screening.

Cell 2 has four work stations and a floor area of 8 by 22 ft and a height of 14 ft. The two east windows share two master-slave manipulators; the two west windows share three manipulators. A bridge-mounted-electromechanical manipulator services the entire cell. The manipulator has a hand with a capacity of 100 lb and a shoulder hook with a 750 lb capacity. A 1-ton chain hoist is installed on the east end of the cell for handling large objects. Because it is equipped with two shielded metallographs and a shielded electron microscope with attached electron dispersive spectrometer, the cell has been dedicated to metallography and related tasks.

Cell 3 has a floor area of 6 by 20 ft and a height of 14 ft. The cell has four work stations, with manual manipulators installed as described for Cell 2. The cell also contains an electromechanical-overhead manipulator and chain hoist of the same type and capacities as Cell 2. Cell 3 is a general-purpose cell where equipment can be moved in for each selected job.

The cells have an air atmosphere, off-gas being passed through HEPA and Silver Zeolite filters. Shielding for the cells is 48 in. of high density concrete. The cells are generally limited to handling experiments no larger than 9 in. outside diameter by 8 ft long with a maximum weight of 750 lb. Work is normally performed in the horizontal position for long specimens, but specimens to 3-1/2 ft long can be handled in the vertical position. The cells contain machine tools, welding equipment, 50-joule

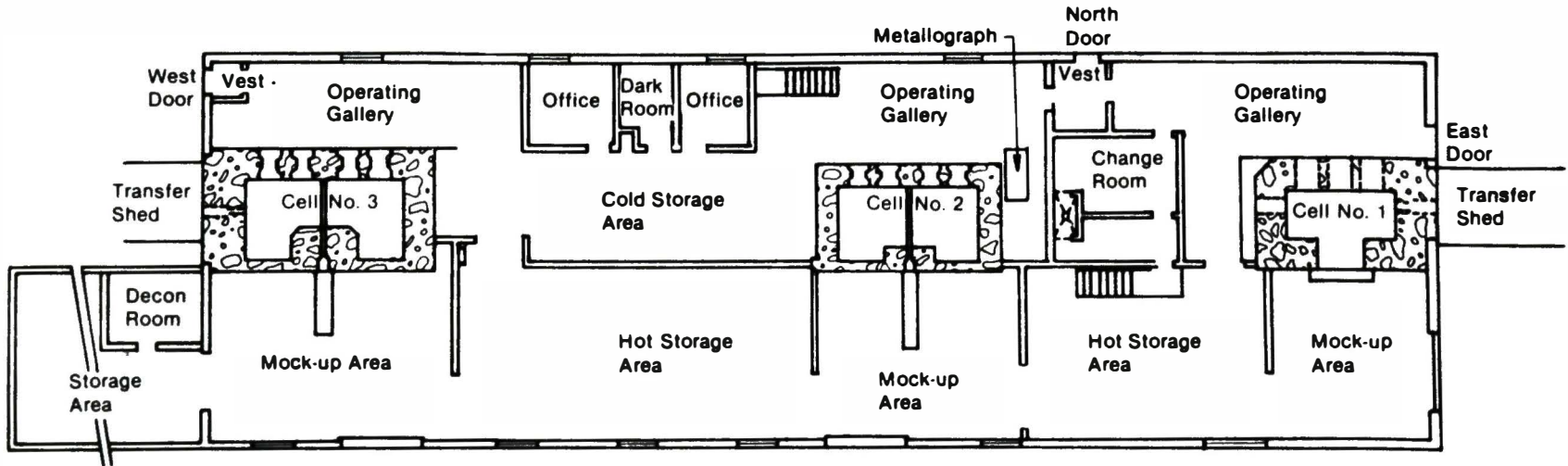

INEL 2 1888

Figure 12. Plan view of TRA hot cells.

pulsed laser, metallographic equipment for mounting, encapsulating, grinding and polishing specimens, and a variety of examination equipment. The examination capabilities of the cells areas follows:

- Photography through cell windows
- Photography through periscope
- Closed circuit TV
- Gamma scans, gross and spectral; maximum specimen length is 60 in.
- Autoradiographs of metallographic samples
- Scanning electron microscopy (100 A resolution, elements with atomic numbers 11 through 99)
- X-ray spectroscopy
- Furnace heating in air atmosphere
- Particle size determination by screen separation and spectroscopy
- Weighing-- 5×10^{-5} to 3×10^3 g
- Density determination by immersion
- Metallographic capability (5X to 1500X magnification, bright field, dark field, polarized light--microhardness testing).

Neutron radiography is not available in the hot cells but is provided within TKA by the Advanced Reactivity Measurement Facility (ARMF). The ARMF offers high quality radiographs of fuel rods, small fuel assemblies, and capsule experiments. The neutron beam is produced by a 100-kW reactor, which generates thermal neutrons for radiography. Assemblies up to 4 in. in diameter and as long as 17 ft can be radiographed in 34-in. increments.

Supporting the hot cells are a decontamination room, mockup area, darkroom, contaminated and clean equipment storage areas, small machine shop for low-level contaminated work, and office space. Complete machine shop capabilities exist within TRA for unirradiated/uncontaminated materials.

2.4.4 Hot Fuel Examination Facility (HFEF)--North and South

The examination facilities identified with HFEF consist of two major hot cells, an analytical laboratory, and a shielded Auger microprobe at the Experimental Breeder Reactor-II (EBR-II). The HFEF-N is an inert atmosphere, alpha-gamma hot cell facility used for destructive and nondestructive examination of irradiated breeder fuels. The hot cell is divided into an air atmosphere decontamination cell of 600-ft² (floor area) adjoining a main argon cell of 2100 ft². Figure 13 is a plan view of the cell showing inside dimensions. The overhead height of the main cell is 25 ft, which can be extended 8 ft by removing a false floor. Shielding for the hot cell is 4 ft of high density concrete.

The decontamination cell contains six work stations, each equipped with two master-slave manipulators, station lights, and electrical and pneumatic feedthroughs. The cell is served by a bridge-mounted-electromechanical manipulator having a 750 lb capacity and a 5-ton bridge crane. A spray chamber for wet decontamination of equipment and other items are contained within the cell. Figure 14 is an elevation view of the equipment in this and the main cell.

The main cell contains 15 work stations equipped with master-slave manipulators, station lights, and electrical and pneumatic feedthroughs. The cell is served by two bridge-mounted-electromechanical manipulators and two bridge cranes, all identical to the ones in the decontamination cell. The cell can handle experiments up to 30 ft long and 2 ft in diameter. The cells contain a variety of machine tools, welding equipment, and examination equipment. Specific examination capabilities of the cell are as follows:

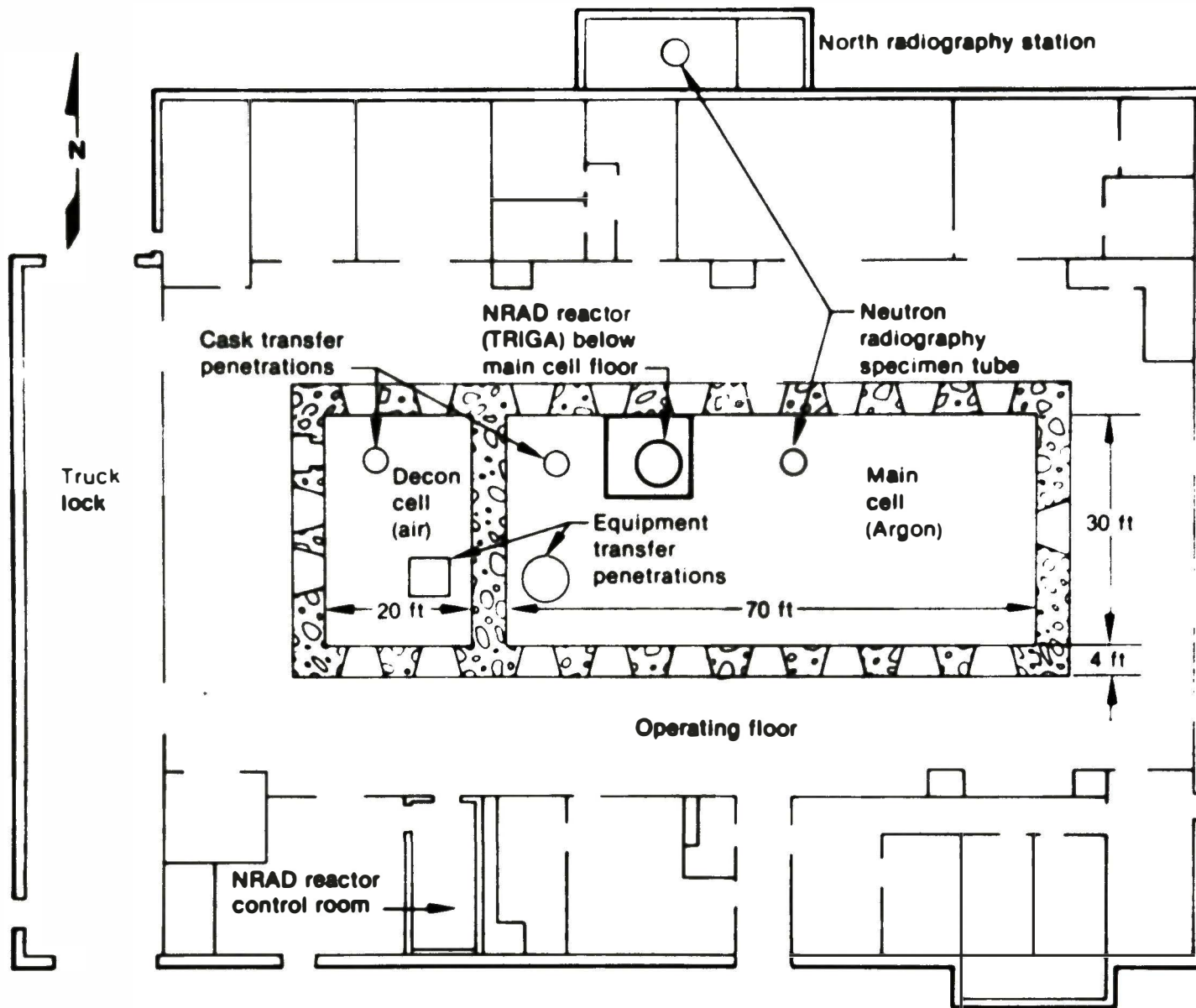

27

INEL 2 1877

Figure 13. Plan view of HFEF-N.

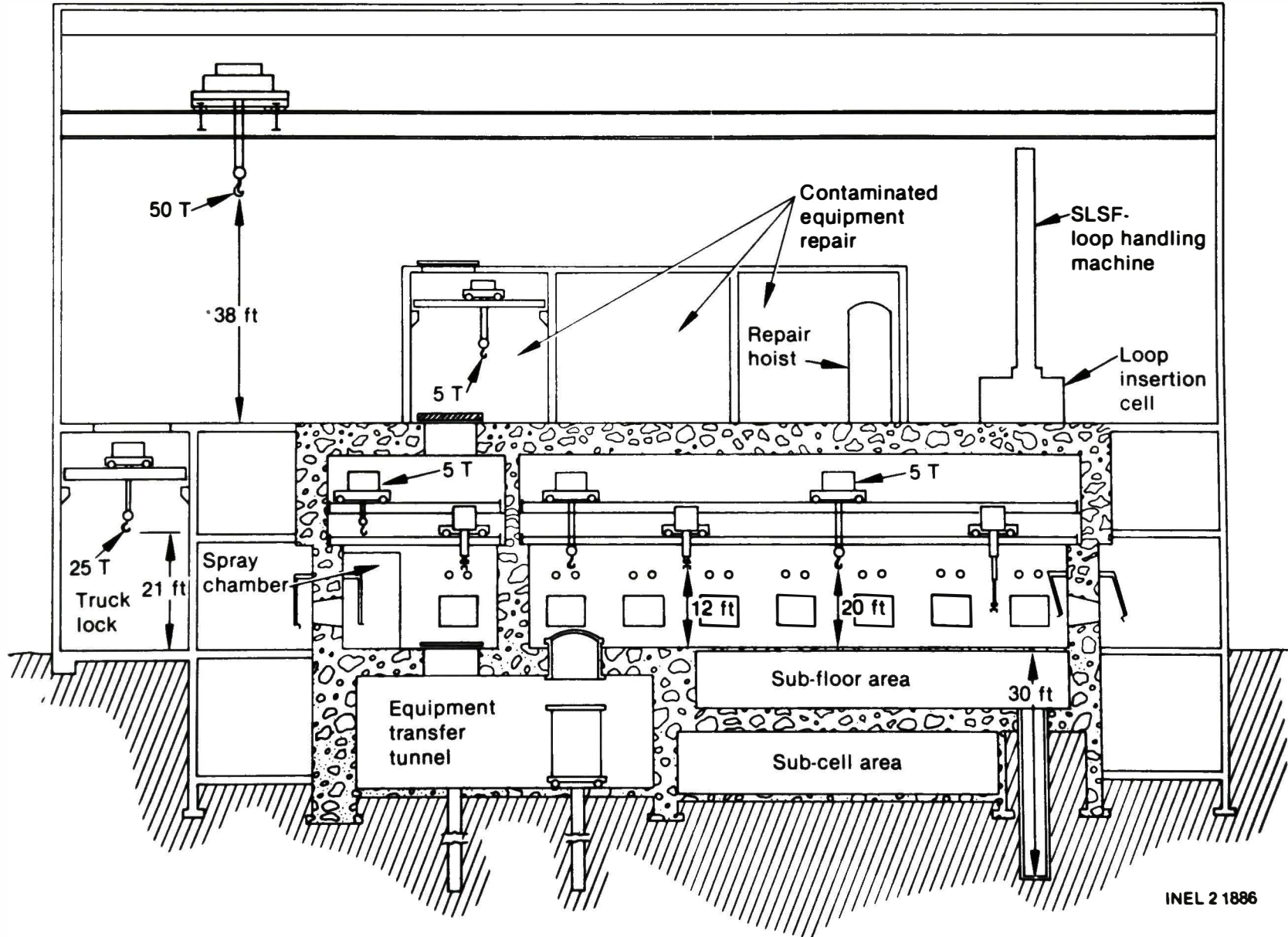

INEL 2 1886

Figure 14. Elevation view of HFEF-N.

- Photography through window with macro features
- Photography through perioscope with macro features
- Closed circuit TV inspection
- Gross and isotopic gamma scans (computer controlled)
- Beta, gamma, and alpha autoradiography
- Neutron radiography
- Particle-size determination by screen separation
- Weighing to ± 0.02 g
- Metallography
- Laser and contact profilometry
- Eddy-current testing.

The HFEF-N contains a neutron radiography facility within the cell. This facility has two specimen-loading stations, one in the main cell and one external to the cell allowing specimen loading directly from the transfer cask without entering the cell. The neutron beam is produced by a TRIGA-FLIP reactor operating at 250 kW. Thermal and epithermal radiographs are produced. The in-cell loading station can accept specimens 6-1/2 in. in diameter by 114 in. long. The external station can radiograph 2-1/2-ft diameter specimens 18 ft long or 1 ft diameter by over 30 ft long.

In addition to the HFEF-N capabilities, the Analytical Laboratory located nearby contains six shielded cells for the analysis of irradiated samples. These cells are 6 ft on a side with master-slave manipulators and viewing windows. The Analytical Laboratory is connected to HFEF-N by a pneumatic-transfer system that can convey small samples between the two

facilities. Specimens can also be loaded directly into the cells from casks. The laboratory has the following capabilities:

- Vacuum fusion
- UO_2 stoichiometry measurement for isotopic distribution
- Density measurements
- Analytical chemistry capability including analysis for composition, physical properties, and impurities
- Radiochemical analysis
- Atomic absorption.

The EBK-II facility located near HFEF-N contains a shielded scanning Auger microprobe to perform Auger electron spectroscopy. This instrument rasters an electron beam over a specific portion of the sample surface. By combining sputter etching with area scanning, a three-dimensional concentration map may be made for all elements with the exception of hydrogen and helium.

Connected to the EBK-II facility is HFEF-S. This facility is divided into an air cell and a 16-sided-polygon argon cell as seen in Figure 15. The air cell has nine work stations equipped with master-slave manipulators. Two bridge-mounted electromechanical manipulators with 750 lb capacity and one 5-ton bridge crane service the cell. The overhead clearance is 21 ft.

The argon cell has 2300 ft² of floor space with a 22-ft high overhead. There are 23 work stations in the cell, 10 presently equipped with master-slave manipulators. Fifteen of the work stations are on the outer perimeter of the cell and eight are located in the cell's inner control gallery. Two 5-ton bridge-mounted cranes and four bridge-mounted-electromechanical manipulators with 750 lb capacity service the cell. Figure 16 is an elevation view of HFEF-S showing the cells and handling equipment.

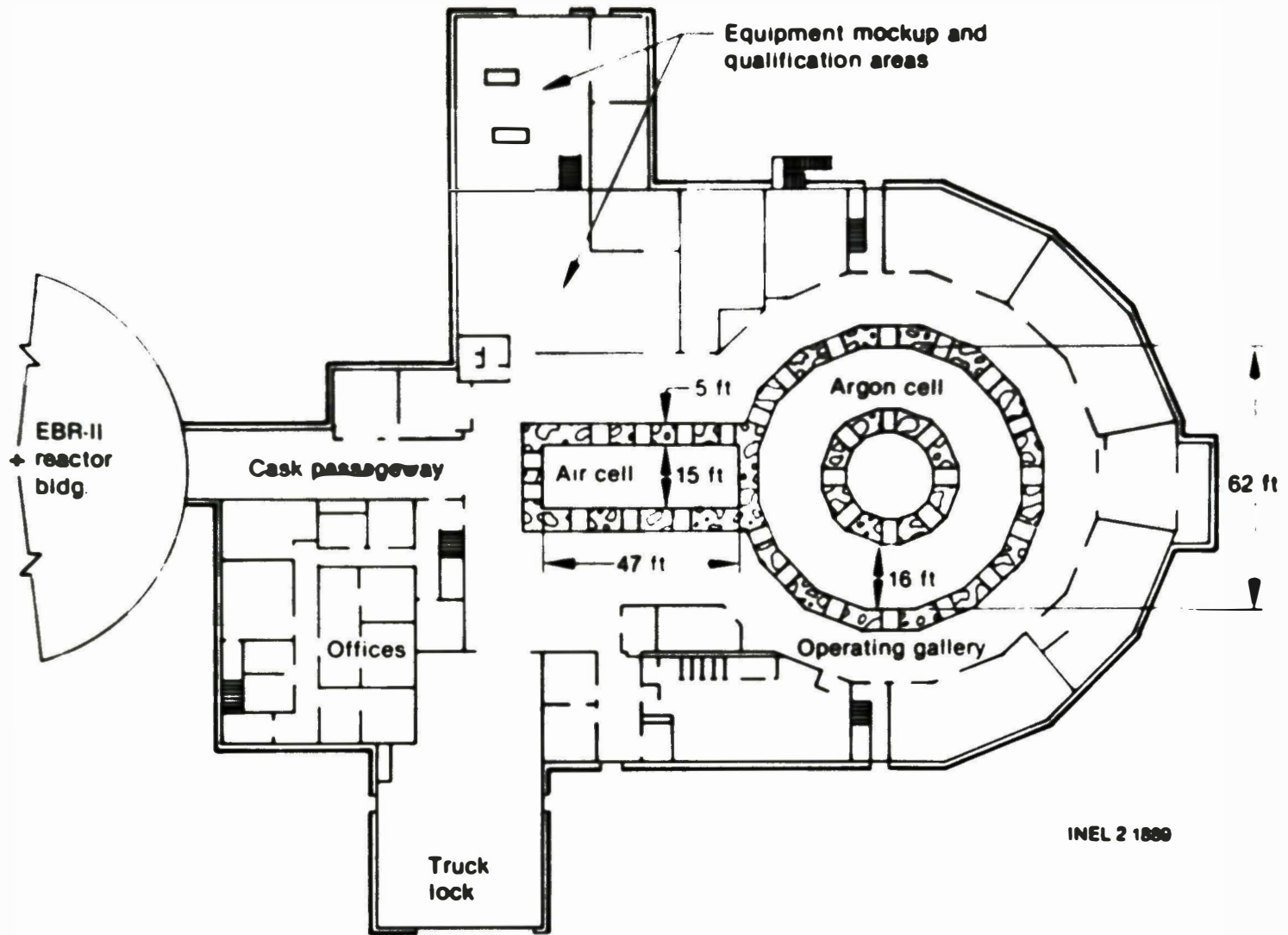

INEL 2 1889

Figure 15. Plan view of HFEF-S.

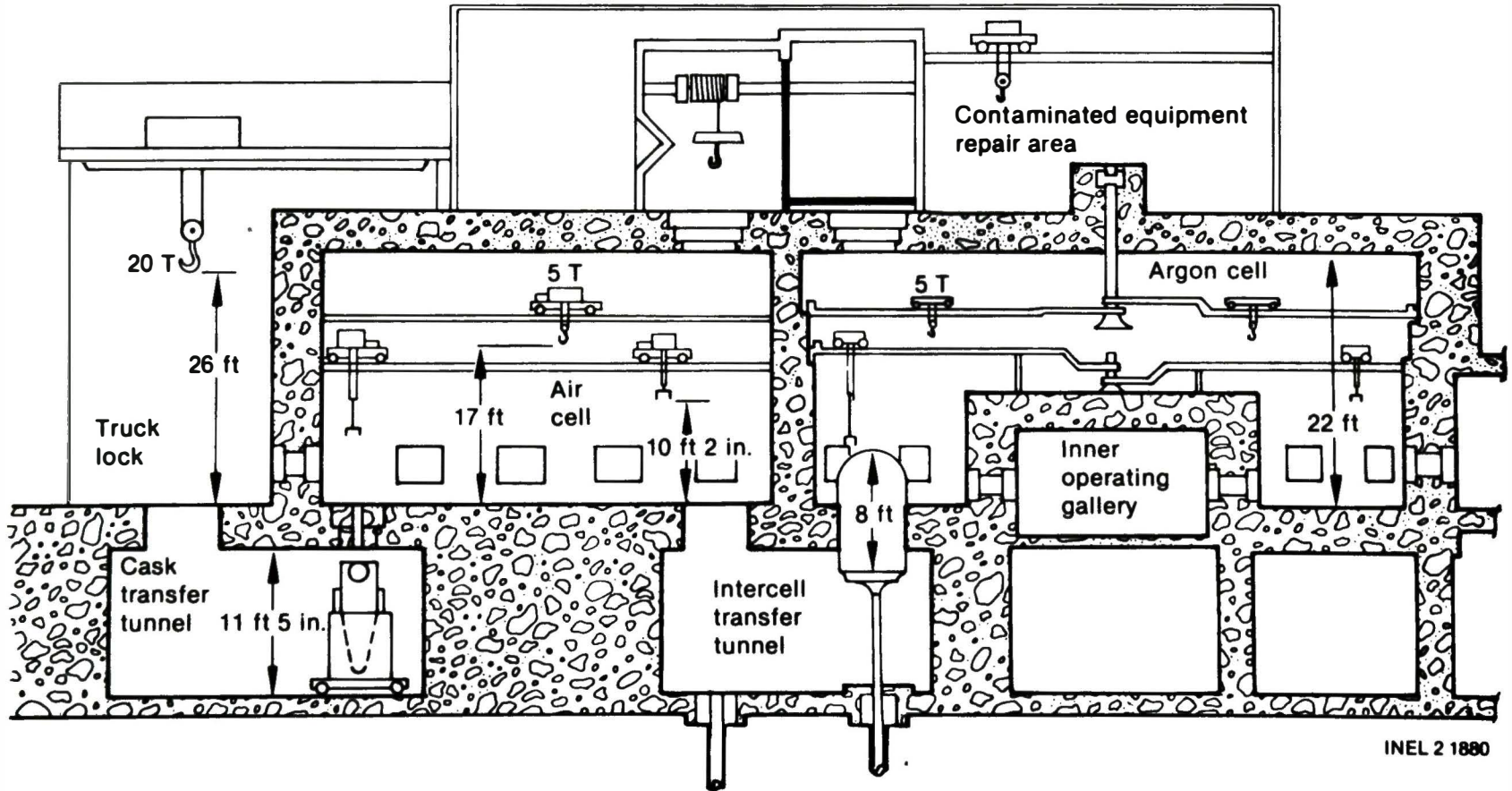

Figure 16. Elevation view of HFEF-S.

The argon cell has been used for fuel reprocessing and fabrication. A large portion of the cell is presently uncommitted to any specific program. It was recently refurbished and is to be used for fuel examination in support of HFEF operations. The facility contains fuel-disassembly equipment, visual examination stations, gamma scanning, eddy current testing, and weighing capabilities.

HFEF-N, HFEF-S, Analytical Laboratory, and EBK-II contain a comprehensive capability in irradiated fuel examination equipment within a single area. Extensive machine shops, mockup test facilities, photo development laboratories, waste handling capability, and offices support these facilities. The facilities are in good condition and ready to accommodate irradiated-fuel-examination missions.

4.4.5 Idaho Chemical Processing Plant (ICPP)

The ICPP contains extensive analytical chemistry capability for irradiated fuel examination within its Remote Analytical Facility (KAF). The KAF consists of a series of 30 stainless steel boxes and an alpha cave located behind 9 in. of steel shielding. Each box is 3 ft on a side and is equipped with a viewing window and two Castle manipulators. There are two rows of boxes facing a center operating corridor; see Figure 17. One row has 16 boxes; the other has 14 boxes and the alpha cave. Each box is designed for one to three specific functions. All boxes in each line are interconnected so that a sample can be transferred from box to box according to the various analyses which need to be performed. The following determinations and operations are performed routinely on radioactive solutions to 50 k: specific gravity, acidity, density, weighing (0.1 mg), filtrations, solvent extraction, separation of uranium for analysis by isotope dilution mass spectrometry and pipetting.

The KAF is a beta/gamma facility, but it has a single cave for handling high-alpha-containing samples. The alpha cave is 6 ft wide by 3-1/2 ft deep and 5 ft high. It has two work stations with master-slave manipulators.

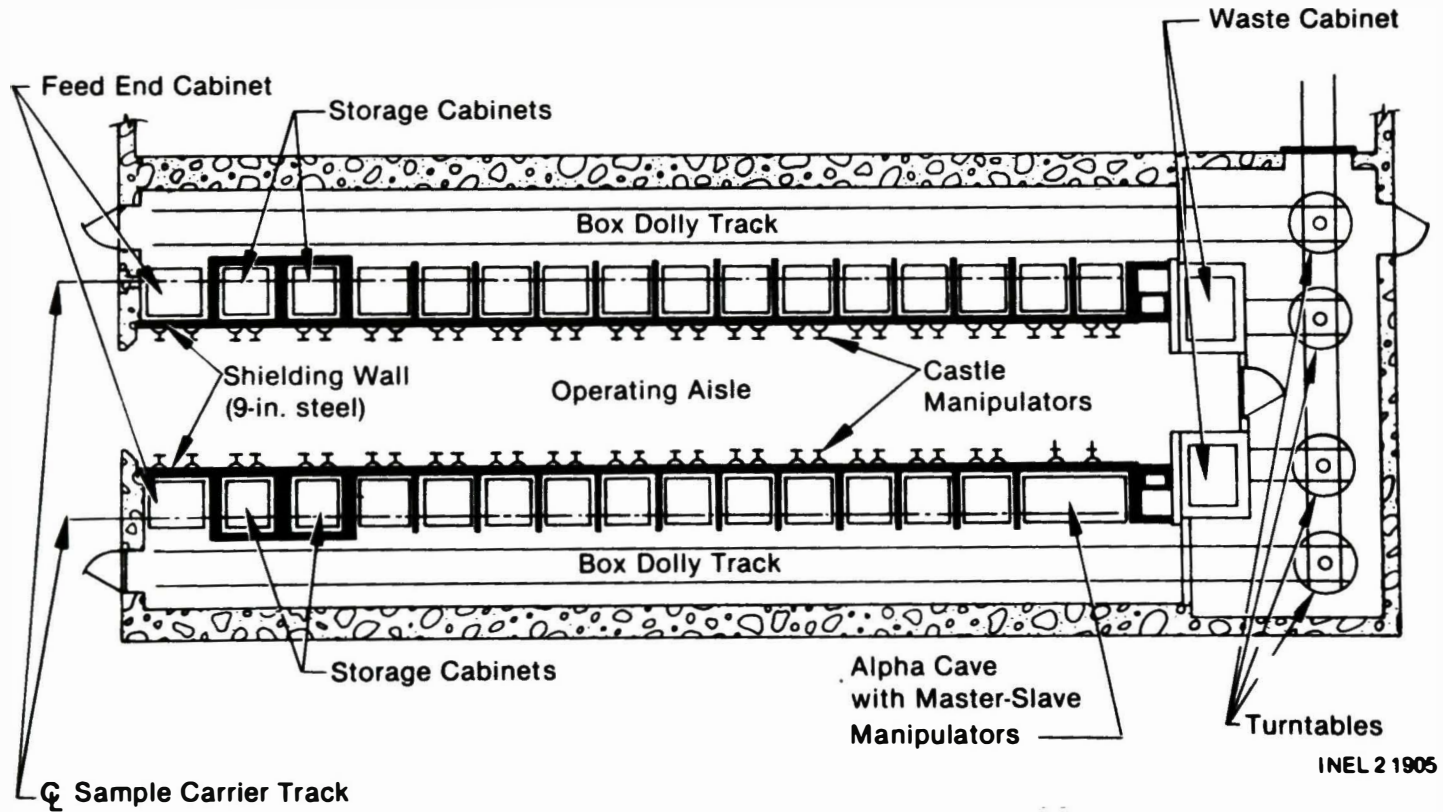

INEL 21905

Figure 17. Plan view of the Remote Analytical Facility.

Each row of boxes in the KAF is connected to a hood and radio-chemistry-bench complex where analyses can be performed after initial pipetting, dilution, or extraction in the KAF to reduce the radiation level of the sample. The activity of the sample aliquot taken into this area must be <100 mR/h at contact.

The KAF can support a full range of analytical chemistry and radio-chemical capabilities. The following equipment descriptions further outline the analytical and radiochemical capabilities of the KAF and related facilities.

- X-ray diffraction^a
- X-ray fluorescence^a
- Auger electron spectroscopy^b
- Scanning electron microscopy^b
- Scanning electron microscopy X-ray fluorescence^b
- Emission spectrography^a
- Spark source mass spectrometry^c
- Atomic absorption spectrometry^b
- Furnace atomic absorption^c
- Inductively coupled plasma emission spectrometry^b

a. radiation levels of ≤ 50 μ R.

b. Radiation levels of ≤ 100 mR.

c. radiation levels may not exceed 10 mR.

- UV/visible spectrometry^C
- Gas chromatography^C
- Gas chromatography/mass spectrometry^C
- High pressure liquid chromatography^C
- Ion chromatography^C
- Thermal analysis^C including thermogravimetric analysis, differential scanning calorimetry, and high temperature differential thermal analysis
- Voltametric techniques^b including pulse polarography, differential pulse polarography, anodic stripping analysis, and controlled potential coulometry.

In 1985 the analytical chemical capabilities for high alpha/beta/gamma sample analysis will be further increased at ICPP by completion of the Remote Analytical Laboratory (RAL). This facility will contain an alpha-tight cell with six work stations, each equipped with master-slave manipulators. A plan view of the facility is shown in Figure 18. In addition to the analyses that are done in the RAF, the RAL hot cell will have X-ray fluorescence and inductively-coupled plasma emission spectrometry capabilities for very highly radioactive samples. The RAL will also provide expanded capabilities for warm and cold laboratory work.

b. Radiation levels of ≤ 100 mR.

c. Radiation level may not exceed 10 mR.

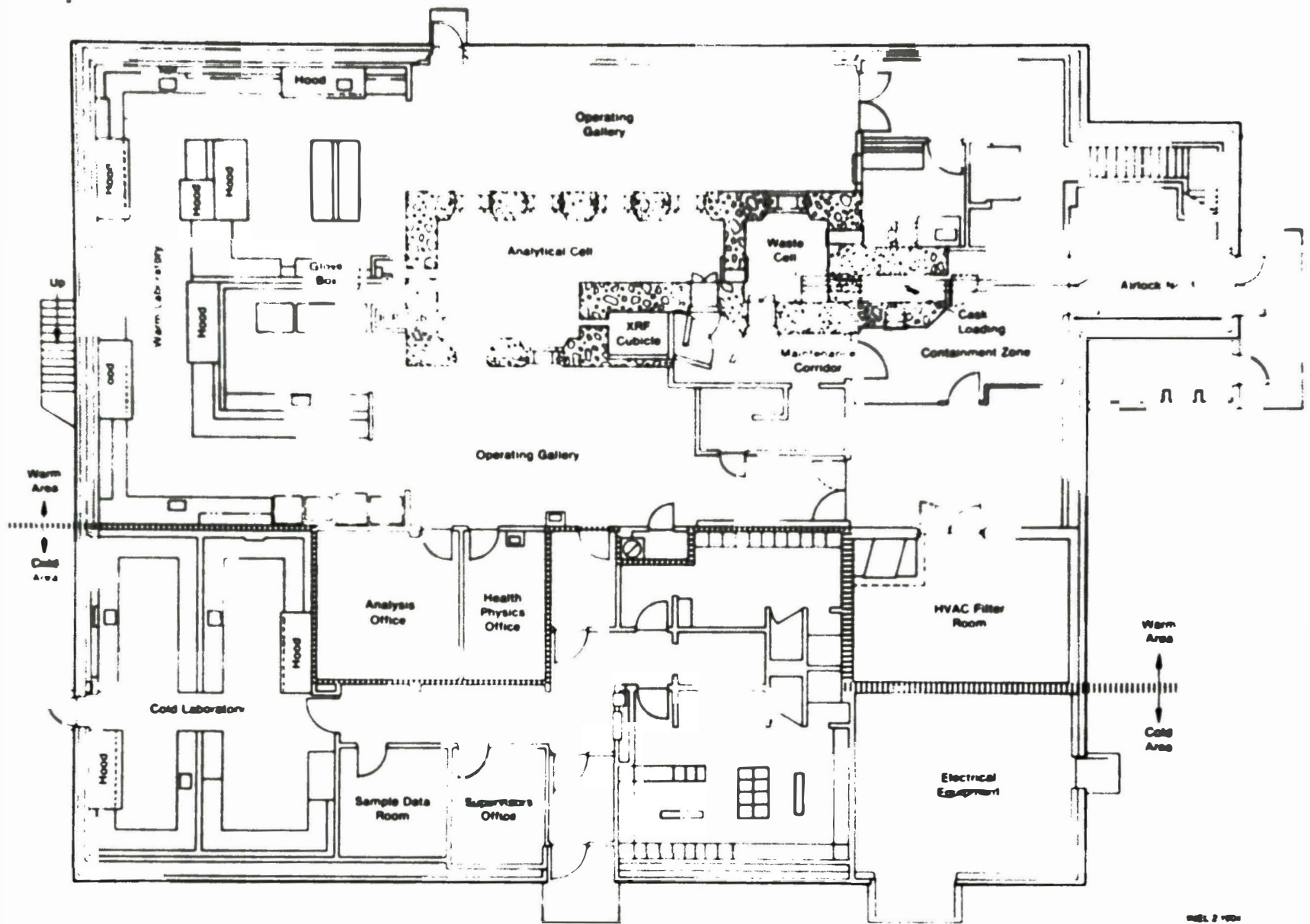

Figure 18. Plan view of the Remote Analytical Laboratory.

3. ADMINISTRATIVE

This section contains a discussion of the administrative documentation identified as necessary prior to or during the receipt of any TMI-2 core materials. This documentation is only applicable to that needed for INEL work. No consideration was given to the documentation needed to transport the core to INEL.

The documentation discussed in this section is applicable only to the receiving and transfer, preparation, and storage operations. That needed for the examination operations is considered minimal. All of the examination facilities routinely handle irradiated fuel in specific casks, and the TMI-2 core fuel will probably not fall outside the existing limits. It is possible that some analysis would be required to ensure that accidents from TMI-related operations fall within the envelope of previously-analyzed accidents.

Three operations are somewhat unique to the TAN-607 facility and must, therefore, be addressed in revised or new documentation.

The administrative areas to be addressed are environmental, safety, safeguards and security, quality assurance, and operations. A general discussion of each area is contained in the following paragraphs. The anticipated costs and schedule for the needed documentation is contained in Section 5.

3.1 Environmental

The data used to evaluate the environmental concerns for the TMI-2 Core Activities Program are contained in Appendix A. These data are somewhat limited because specific information does not exist on the quantity and composition of material to be received, the processes for examination and treatment of wastes that will be generated, the time frame for storage at INEL, and any construction that may be necessary for the proposed program. (None of the latter is anticipated.)

Based on the existing data, it does not seem likely that an environmental impact statement (EIS) will be required for the INEL on-site activities which are necessary for examination of the TMI-2 core. The previous statement is based on the following assumptions:

1. Environmental documentation will cover only INEL site activities-- preparation and transportation of the core are assumed to be covered by the NRC programmatic EIS¹ or will be covered by separate documentation.
2. The TMI-2 core examination and environmental documentation are under the jurisdiction of DOE-ID.
3. The environmental impact from on-site activities will largely be confined to the INEL site, and off-site populations will not be exposed to significantly increased quantities of radiation or toxic materials. An environmental evaluation (EE) or an environmental assessment (EA) will determine the validity of this assumption. If the assumption is invalid, an EIS would probably be required.
4. A major reprocessing facility will not be constructed as part of the Core Examination Program.

If these assumptions are correct, a detailed environmental assessment (EA) or, at the discretion of DOE-ID, an environmental evaluation (EE) would be sufficient to adequately meet the requirements of the National Environmental Policy Act (NEPA). The depth of analysis in an EA or EE for core examination will be very similar. However, an EA is a public document as specified by the NEPA implementation regulations (40 CFR 1500-1508); an EE is an internal DOE document subject only to DOE-ID approval. Again, DOE will make the final decision on these documentation requirements.

The time required for preparation of an EA or EE will depend on the scope of the project and the amount of specific information available. Although the actual preparation time for the EA or EE will be similar,

public and agency review of the EA, as well as publication of a finding of no significant impact (FONSI), will lengthen the EA process. A rough time schedule and cost estimate for preparation of an EA or EE, based on time requirements for other TMI and INEL site EEs, is given in Section 5. A detailed description of the project, including waste characterization, construction requirements, processing and storage location, storage area parameters, alternative processing techniques, and radiation source terms, is needed before an EA or EE can be prepared.

Preoperational monitoring is required by DOE 5484.1 for new facilities that have the potential for adverse environmental impact or that will process, release, or dispose of pollutants. TAN, however, has been well characterized for radiological contaminants, and a preoperational program should be minimal. It is anticipated that new programs will pay a percentage of the total environmental monitoring program cost.

3.2 Safety

3.2.1 Documentation

The receipt and handling of the TMI-2 core materials falls outside the envelope of most existing safety documentation at the TAN-607 facility. Although all major documents are in place at TAN, they will have to be revised to reflect the conditions and criteria of the TMI-2 fuel and the Core Activities Program. The TAN Safety Analysis Report (SAR) will be one of the first documents to be reviewed and necessary revisions made. Some specific areas that should be included in this review are listed below:

- Radiological impacts associated with normal, abnormal, and accident conditions

- Evaluation of shielding

- Evaluation of risks associated with accidents from natural phenomena

- Evaluation of effluents
- Emergency preparedness requirements
- Criticality operational controls.

In general, the SAK should show that the TAN-607 facility can be operated for use in conjunction with the TMI-2 Core Activities Program without undue risk to the health and safety of the public, and with adequate provisions for protection of property and the environment.

The TAN-607 Operational Safety Requirement Document will need to be reviewed and revised appropriately. This document should define the conditions and management controls needed to ensure safe operation of the facility when handling the TMI-2 core materials.

The TAN-607 hot Shop, TAN Hot Cell, and storage pool are presently established as Fissile Material Control Areas (FMCA). A separate Criticality Safety Evaluation (CSE) has been performed on each of these areas for anticipated operations. Since the TMI fuel has not previously been considered in facility operations, all affected CSEs will require review and revision where necessary. In addition to the CSE, an Independent Criticality Analysis (ICA) is required to detect errors that are difficult to identify except by duplicate calculations.

Prior to receipt of the first fuel shipment from TMI, a Radiological Hazards Analysis (RHA) must be prepared by the Safety Division. This is an analysis of the expected exposure rates and of any hazards associated with receiving and handling fuel where high exposure is possible. In order to perform this analysis, an irradiation history of the fuel and the fuel content in the canisters are needed.

Other documentation that may be prepared or approved by the Safety Division are as follows:

- Site Work Release (SWR)--This document is a work authorization that also contains provisions for recognition of hazards.
- Safe Work Permit (SWP)--This document describes significant and unusual hazards expected during conduct of work, and identifies required procedures. All work around hot cells, loading, or unloading casks require an SWP.
- Detailed Operating Procedures (DOPs)--DOPs are written as a work directive with step-by-step sign-off. They are required for all work performed in the hot cells and related facilities.
- Transport Plans--It is assumed that any on-site fuel shipping will be done in existing casks with approved existing transport plans, and that the TMI fuel will fall within the limits of the plan. Given these assumptions, little work should be needed for transport plans.

3.2.2 Reviews

Committees are required to perform specific reviews of safety-related documentation and facility operations. The major review is a readiness review held prior to receipt of any fuel. This review is the final check to ascertain that all documentation is in place and that facility work needed for receipt of fuel has been completed. The readiness review committee is selected by the facility operations manager.

All criticality analyses must be reviewed and approved by the Criticality Review Committee (CRC). The CRC also reviews all criticality safety control procedures for handling and storage of fissile materials.

The Operational Safety Review Committee (OSRC) serves as an independent review agency on matters pertaining to review and approval of proposed hot cell work that involves high hazard potential.

Independent review and approval must be obtained from the Safety Division for all potentially hazardous aspects of the program. This includes work as early as the conceptual design stage and applies through startup and operations.

3.2.3 Training

Site personnel are presently trained and certified for hot cell work. Additional training, however, will be required for working with the TMI-2 core debris. Any person responsible for shipping TMI fuel to other on-site or off-site locations must have Radioactive Shippers' training and be certified as a radioactive shipper. Likewise, individuals assigned to handle fissile material without direct supervision must have Criticality Safety Training and be certified as Fissile Material Handlers (FMH).

3.3 Safeguards and Security

The Safeguards and Security requirements for the TMI-2 core materials are not felt to be extensive, because of the high radiation fields present, the physical form the special nuclear material (SNM) is in, and the low enrichment of the fuel. This is confirmed by DOE Order 5632.2, which allows reduction in physical protection for SNM for either of the first two conditions.² If the radiation field for the material decays below 100 R/h at 1 m, the fuel is then defined as Category III-B material, per 5632.2 because of its low enrichment. In either case, the security protection for receiving, handling, and storage has to meet only the DOE Operations Office approved Safeguards and Security Plan rather than the detailed requirements of 5632.2. This plan is a description of the systems and procedures implemented to protect the SNM. It is prepared by the Safeguards and Security Division and submitted for DOE approval. For this category of material the plan is generally brief.

Accountability of the fuel material will be required. However, because of low enrichment and high radiation, it will be treated as Category III Special Nuclear Material per DOE Order 5630.2, Reference J. In any case the provisions of the Nuclear Material Custodian Handbook⁴ must be met.

For accountability purposes an engineering estimate of the gram fuel content for each canister must be made. The GPU estimates, made in compliance with shipping requirements, will be used as the basis for storage, examination, and accountability while the fuel is at INEL. Should the material be subdivided for examination, estimates of the gram quantities of fuel contained in each portion must be made and recorded in the Nuclear Material Custodian's records.

Semi-annual Physical Inventory Verifications will be limited to a count of the fuel-bearing canisters, verification of their serial numbers (as appropriate), and a records review. Subdivided canisters will be subject to records review and identification of each of the subdivided parts. In the event better fuel content values are generated through programmatic examination or recovery activities, the accountability records will be updated to reflect the more correct information.

Existing INEL procedures for storing the material in an administratively-controlled area should be sufficient. The INEL regulations for shipping radioactive/fissile material are also adequate for handling the TMI fuel. No extraordinary precautions beyond normal INEL procedures are believed necessary for any of the examination operations.

3.4 Quality Assurance (QA)

QA requirements beyond those necessary to accommodate existing INEL programs will not be required for the TMI-2 Core Activities Program. Present quality program plans are adequate for the Core Activities Program. Specific areas where QA involvement is required are as follows:

- Inspections for shipping damage on arrival
- Inspections of all handling equipment
- Leak testing core debris repackaged for shipment or storage
- Inspection and identification of any core debris shipment package.

In addition to the above, an identification and cataloging system should be developed. This system shall prioritize specimens to be inspected according to QP-14. Records shall be kept in accordance with QP-17. These activities need not be performed by QA personnel. They are the responsibility of the program manager and shall be a part of configuration control plan.

3.5 Operations

The major administrative tasks for operations are preparation of Detailed Operating Procedures (DOP), revisions to the existing Operations and Maintenance Manual (OMM), and training. Operations is also responsible for scheduling a readiness review prior to receipt of the examination samples.

4. TRANSPORTATION AND CASKS

Receiving TMI-2 core materials and moving sample materials from one INEL facility to another require transportation capabilities as casks, roads, and railroads. This section of the report contains a review and an identification of those capabilities available at the INEL.

4.1 Casks

A large number of existing INEL casks were reviewed to determine which are able to carry examination samples and canisters from one site location to another. The data are summarized in Table 1. From the data, it is evident that only one cask is available that can handle a 14-ft long canister. The loop handling machine (LHM) could load a canister with proper adapters, but it is limited to facility interfaces at HFEF-N and the ETR. It is a bottom-loading cask and must be loaded vertically. With the proper docking hardware, the cask could be loaded and unloaded at TAN-607 or the FAST Facility. Other INEL hot cells could not handle the LHM without major modifications either to the cells or to the cask.

It is apparent that moving a 14-ft canister in INEL casks will be difficult and limited by facility capability and cask interfaces to specific facilities. Since the TAN-607 facilities could repackage the core materials, the limitations and difficulties do not seem to be a problem. It is possible to move a canister, if necessary, with the LHM. It might be worthwhile to build an adapter for the LHM, because it would allow direct interfacing with HFEF-N. This would solve the potential problem discussed in Section 2, if HFEF-N is required to receive full-sized canisters.

Smaller core examination samples could be transported from one INEL facility to another in any of several casks. These are also shown in Table 1. They include a single family of small casks called "Hot Cell Sample" casks. It is evident from this list that there are many options for moving sample materials. All casks in Table 1 are certified for transportation of fissile material between INEL facilities. All have transporters available on-site.

TABLE 1. INEL CASK DATA

Cask Number (Owner or Program)	Total Weight (T)	Internal Dimensions		Shielding		Maximum Cask Loading		Facility Interfaces	
		Length (in.)	Diameter (in.)	Material	Thickness (in.)	U235 Fissile Material (kg)	Decay Heat (W)	From	To
LHM (ANL)	46	360	20	U	4	5.9 ^a	100	HFEF	ETR
TFBP-2 (PBF)	25	163.75	9.75	Pb	5.3	0.4		PBF	MTR, TAN, ARA-1, TRA
HFEF-4 (ANL)	13	94	4	Pb	14	6	1000	HFEF	ICPP
White elephant #2 (THA)	10.8	61.5	6	Pb	10.3	1.3	1000	ETR, TRA	TAN, AHA-1, HFEF
T-2 (ANL)	10	71	3.75	Pb	9.5	1.71 ^b	208 U-Pu ^b	HFEF	TAN
RM-16 (ANL)	14	65	5	Pb	14	0.4 ^c	150	HFEF	TRA, TAN
Hot cell sample (INEL)	0.2 to 4.8	4.2 to 14.5	1.6 to 7.75	Pb	--	0.4 ^c	--	INEL	INEL

a. Pu.

b. U-Pu mix.

c. Or equivalent.

4.2 Railroad Facilities

There are no railroad facilities at TAN or HFEF that connect to an interstate rail line. If the TMI core canisters are to be shipped by railroad to the INEL, they will have to be off-loaded at another facility and trucked to TAN-607. There are railroad-receiving facilities at the Central Facilities Area (CFA), Radioactive Waste Management Complex (RWMC), ICPP, and the Naval Reactor Facilities (NRF). All of these facilities have cranes with a 70- to 100-ton capacity; any of them could off-load rail casks onto suitable truck transporters for movement to specific facilities.

4.3 Roads and Bridges

According to a review of the roads and bridges on the INEL site, casks and transporters weighing as much as 100 tons can travel without clearance problems and without exceeding the load limit.

5. PROJECT PLAN, COSTS, AND SCHEDULES

This section contains a project management plan, costs, and schedules for the work of preparing INEL to receive core materials. This is a preliminary project plan. Some of the sections have not been prepared because the specific requirements cannot yet be defined. This facility readiness work plan presents enough information to demonstrate the feasibility of performing the TMI-2 Core Activities Program at INEL. The data from this plan will be incorporated into the TMI-2 Technical Support and Projects Office Program Plan.

Neither the project plan nor costs for the actual Core Activities Program are included in this section. Items such as hot cell costs for material handling and sample examination must be derived from the post-irradiation examination plan, which is not available at this time. Other expenses, such as those associated with the Environmental Monitoring Program, fuel storage, HP surveillance, etc., are to be included in the examination and storage costs.

5.1 INEL Facility Readiness Project Plan

Data acquisition concerning the accident sequence at the Three Mile Island Unit-2 (TMI-2) facility is a primary concern to the nuclear industry. As part of a nationwide study, examination and analyses of core debris will be performed at INEL. These examinations are to provide analytical information necessary to understand the TMI-2 accident sequence. They will also provide a data base that can be used to predict nuclear fuel behavior during degraded-core-cooling situations, and possibly identify areas for design improvement.

As part of the TMI-2 Core Activities Program, the status and capabilities of the INEL facilities that might be used for fuel examination were reviewed. Three types of facilities were considered necessary: receiving, storage, and examination. The review determined what capabilities or deficiencies exist at the facilities and identified the administrative requirements for receipt of the core examination samples.

5.1.1 Project Objectives

The INEL readiness project developed three types of objectives:

- Technical--The project will prepare INEL facilities to safely receive, store and, examine the TMI-2 core. These preparations shall include physical modifications to facilities as well as procedures and personnel training needed to handle the casks, canisters, and core samples.
- Schedule--The TMI-2 core materials are scheduled to start shipment to the INEL in early FY-85. All preparation for receipt of the core materials should be done by the end of FY-84. Preparations for sample material handling and examination should largely be completed in FY-85.
- Cost--Funding for the project will come from operating and capital equipment funds. Since a number of other programs will also be using the facilities, only those modifications and facility operations needed for receipt, storage, and examination of the TMI-2 core shall be funded by this program.

5.1.2 Work Plan

The work scope in this plan covers preparations necessary to receive the TMI core. Costs for examination and handling the sample materials are covered in other plans.

The work is divided into administrative and facility-modification tasks. Administrative tasks consist of preparing documentation needed to receive, handle, examine, and store the TMI-2 materials. This documentation includes safety analyses, environmental analyses, detailed operating procedures, operational-safety requirements, security plans, quality assurance, and training.

Modifications needed to ensure safe handling and storage of the samples may be made to any of the facilities. These tasks may be costed to capital equipment or operational funds, as appropriate. A modification may be an actual change to the facility, maintenance on a facility's equipment item, an equipment-item upgrade, or design and fabrication of a handling tool.

The work will be done according to project-management and systems engineering techniques. A project manager shall control costs and schedule requirements. A systems engineer shall ensure that technical criteria, codes, standards, and specifications are integrated into all phases of the project. In addition, the systems engineer shall perform trade-off studies and address interfaces with other TMI-2 activities, e.g., canister design.

Planning for the project is developed in a detailed work breakdown structure (WBS). The WBS divides and subdivides project activities into manageable tasks that can be accurately costed and scheduled. The work will be controlled by individual functional organizations and approved by the Technical Support and Projects Office. The functional organizations shall write work packages and be responsible for work in their area of expertise.

5.1.3 Project Definition

Figure 19 shows the project WBS. It gives an organized definition of the necessary project work. It is a product-oriented structure containing analytical studies, services, and construction projects. The tasks and elements that compose the WBS are discussed in more detail in Appendix C.

5.1.4 Schedule

Figure 20 presents an abbreviated schedule. This schedule shows the lead time necessary to complete the tasks defined in the WBS. It assumes that the first core canisters will be delivered to INEL in August or September 1984. Also critical is the date the core-debris characteristics

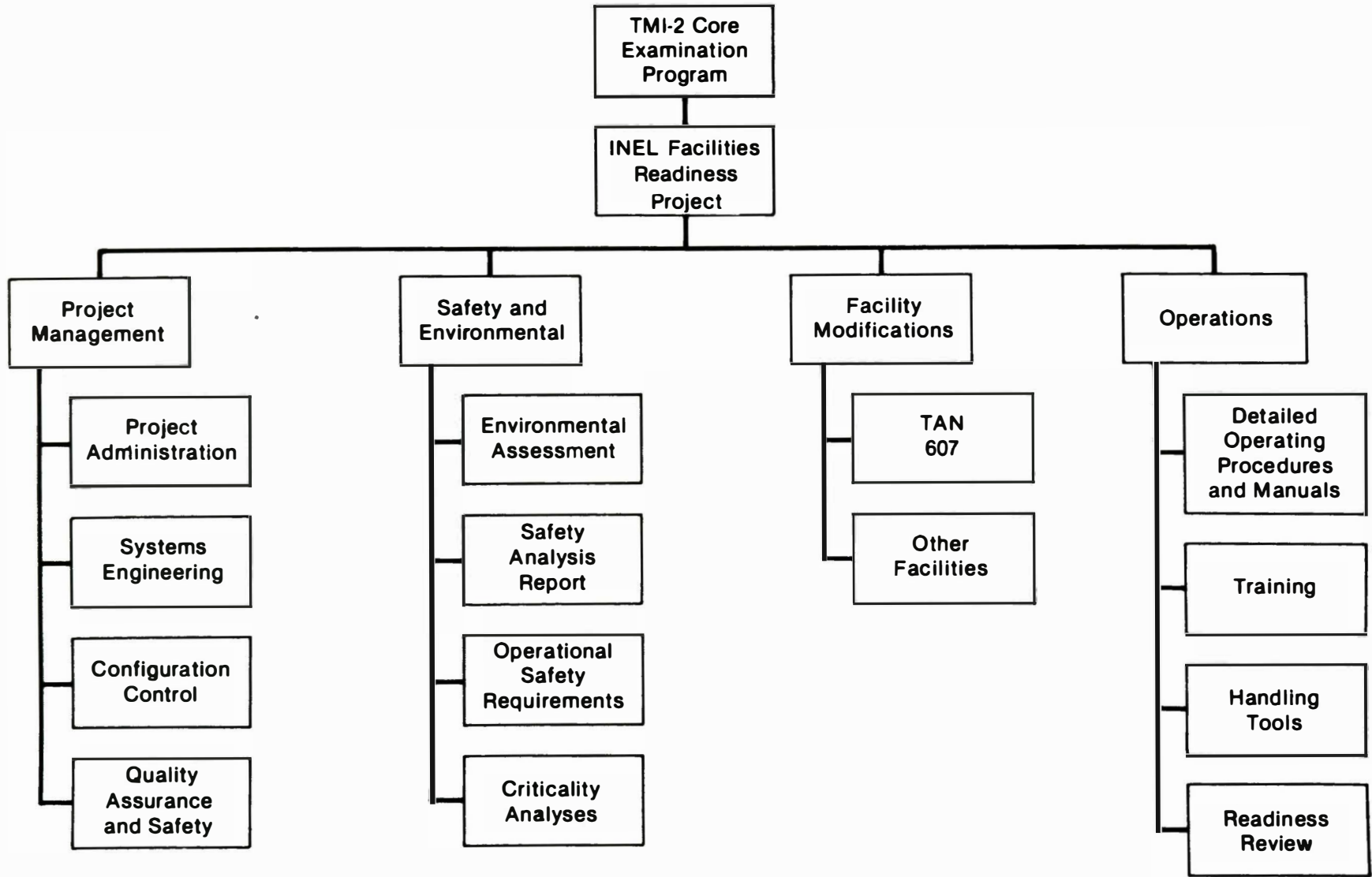
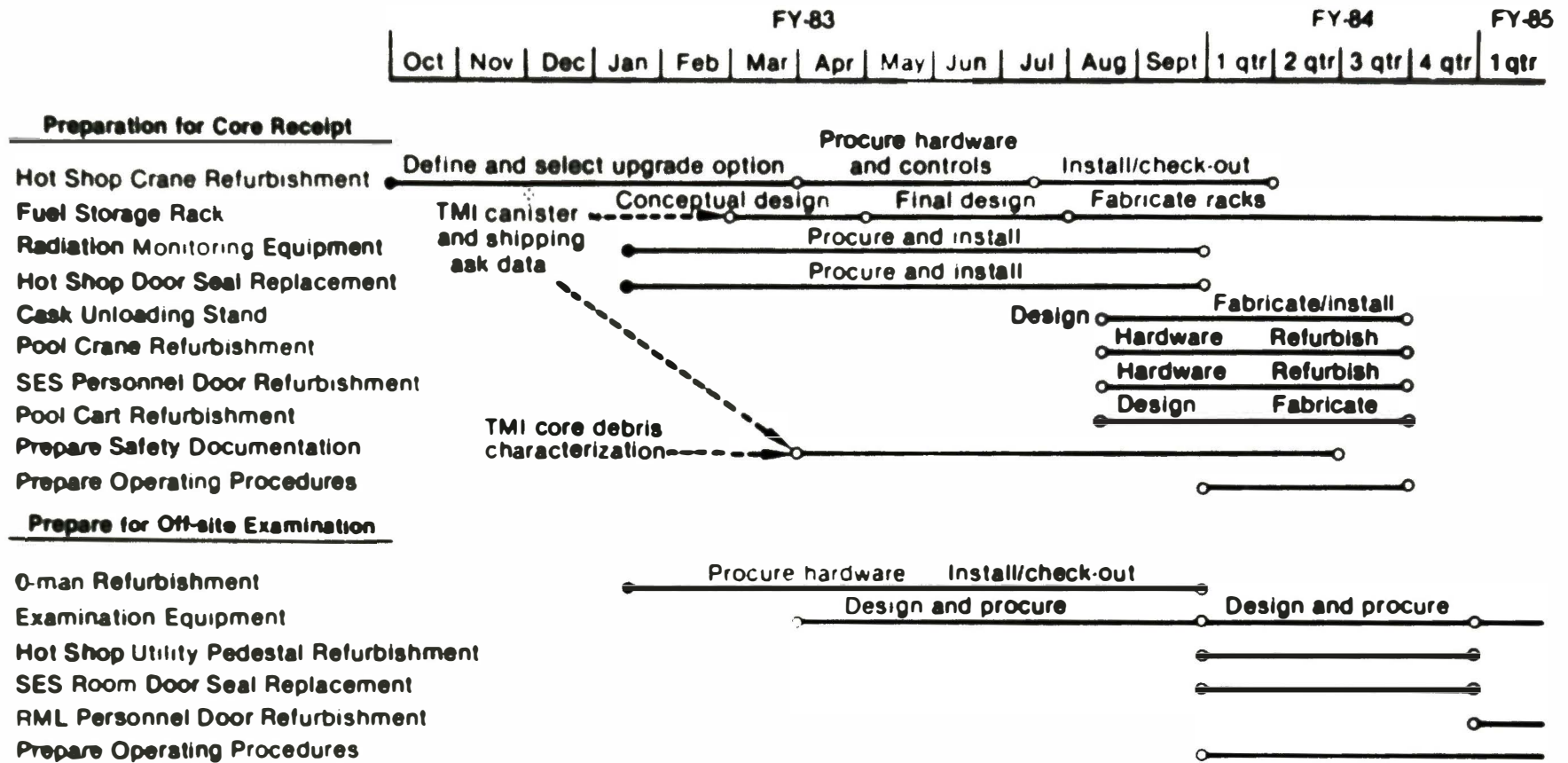

Figure 19. TMI-2 core examination program's INEL facility readiness plan work breakdown structure.



Critical path item from TMI

INEL 2 2196

Figure 20. INEL facility readiness project schedule.

must be delivered so that the criticality, environmental, and safety analyses can be initiated. There is a three-month slack period from the beginning of the readiness review to delivery of the first canister. This allows time for incorporation of the readiness-review committee's comments and for DOE-ID review. Another critical item appears to be fuel storage racks for the TAN-6U7 storage pool. In order to deliver the first racks in 1984, the design and criticality analyses must start in mid-FY-83. This requires that the core-debris-characterization data as well as the shipping canister design data be available at that time.

If the TMI core debris can be characterized before the administrative document start dates, work can begin on these documents at that time rather than at the later dates shown on the schedule.

5.1.5 Costs

Table 2 identifies specific tasks to prepare the facilities for receipt and examination of the core. Estimated costs and completion dates for these tasks are identified where applicable. Costs for documentation and procedure preparation have not been determined, but will be identified later.

Appendix D contains a brief description of the scope of these modifications as they are now known. Work continues to update the scope of the modifications and the cost estimates.

TABLE 2. FACILITY AND EQUIPMENT PREPARATION FOR CORE ACTIVITIES PROGRAM

Description	Cost (\$K)	Estimated Completion Date
TASKS IN PREPARATION FOR COKE RECEIPT		
Refurbish TAN-607 Hot Shop crane	555	12/1/83
Design and fabricate fuel storage racks	460/975	FY-83/FY84 4/1/85
Repair radiation monitoring equipment	155	10/1/83
Replace TAN-607 Hot Shop door seal	130	10/1/83
Fabricate and design cask unloading stand	25	7/1/84
Refurbish pool crane	40	7/1/84
Refurbish SES personnel door	40	7/1/84
Refurbish pool cart	25	4/1/84
TASKS IN PREPARATION FOR COKE EXAMINATION		
Refurbish TAN-607 overhead manipulator	185	12/1/83
Prepare examination and sample handling equipment (aggregate)	1,260	10/1/86
Refurbish Hot Shop utility pedestal stand	375	10/1/84
Replace SES room door seals	430	10/1/84
Refurbish THC personnel door	95	10/1/85

6. REFERENCES

1. Final Programmatic Environmental Impact Statement Related to Decontamination and Disposal of Radioactive Wastes Resulting from March 28, 1979, Accident Three Mile Island Nuclear Station, Unit 2, NUKEG-0683.
2. "Physical Protection of Special Nuclear Materials," U.S. Department of Energy, Order DOE 5632.2, February 16, 1979.
3. "Control and Accountability of Nuclear Material, Basic Principles," U.S. Department of Energy Order DOE 5630.2, August 21, 1980.
4. Nuclear Material Custodian Handbook, EG&G Idaho, Inc.

APPENDIX A
TMI-2 CORE CHARACTERISTICS

APPENDIX A
TMI-2 CORE CHARACTERISTICS

The parameters below provide a description of the original TMI-2 core, and an assessment of current core conditions.

Original Core¹

Reactor type Pressurized Water Reactor (PWR)

Fuel assembly

Number	177 in modified 15 x 15 array
Length	165.625 in.
Cross Section	8.587 in. sq.

Enrichments (3)	1.98%
	2.64%
	2.98%
	2.57% core average ²

Fuel rods

Active length	144 in.
Outside diameter	0.440 in.
Pitch	0.568 in.
Rods/assy	208

Control rods

Control rod assy's/core	61
Control rods/assy	16
Outside diameter	0.440 in.

Axial power shaping rods

APS rods assy's/core	8
APS rods/assy	16
outside diameter	0.440 in.

Burnable poison rods

Poison rod assy's/core	68
Poison rods/assy	16

Materials

Fuel	UO ₂
Fuel rod cladding	Zircaloy 4
Ceramic spacer	ZrO ₂
Spacer grids	Inconel 718
Control rod poison	80% Ag, 15% In, 5% Cd
Control rod cladding	304 SST
Axial power shaping rod poison	80% Ag, 15% In, 5% Cd
Axial power rod cladding	304 SST
Burnable poison rod poison	AL ₂ O ₃ -B ₄ C
Burnable poison rod cladding	Zircaloy 4

Present Core

Rubble bed^{3,4}

Estimated temperatures in the core probably oxidized and embrittled the fuel rod cladding. Any fuel pellets in contact with molten cladding would dissolve, forming a liquid phase zirconium-uranium-oxygen mixture. The estimated temperatures would also have melted the Inconel spacer grids,

stainless steel core components, and Ag-In-Cd control material. Other components in the core region were the $AL_2O_3-B_4C$ poison rods, gadolinia- UO_2 rods from two test assemblies, beryllium-nickel brazements, and instrumentation. Quench water is thought to have fractured the embrittled fuel rods during quenching of the cladding and fuel. This would form a debris bed several feet deep which contains the materials discussed above. It is generally concluded that 40 to 50 % of the core is fragmented and that the size of the fragmented particles will range from a few microns to a few centimeters, with the bulk of the material in the millimeter-to-centimeter range.

Fuel assembly stubs^{3,4}

The rubble bed described above is expected to lie on top of the intact stubs of fuel assemblies. The fuel assembly stubs may be 3 to 6 ft long at the core centerline and longer near the core periphery.

Fuel assemblies intact⁴

Current evidence, although limited, supports the theory that intact fuel assemblies exist at the periphery of the core.

Quantity of debris and intact rods³

Debris	140,000 to 184,000 lb (63,500 to 83,500 kg)
Intact rods and stubs	70,000 to 113,000 lb (31,750 to 51,250 kg)

Core fuel mass

UO ₂	180,560 lb (81,900 kg)
Pu	330 lb (150 kg)

Decay heat

Maximum ²	0.32 watt/kg
Minimum ⁵	0.10 watt/kg

Radiation

10⁶ to 10⁷ R/h on contact (entire core)
10³ to 10⁴ R/h on contact (canisters)

Fission product inventory²

Calculated for entire core

Elapsed time since shutdown--1.8 x 10⁸ s (5.7 years)

<u>Fission Product</u>	<u>(Curies)</u>
Krypton 85	6.69 x 10 ⁴
Strontium 90	6.99 x 10 ⁵
Yttrium 90	6.99 x 10 ⁵
Ruthenium 106	5.78 x 10 ⁴
Rhodium 106	5.78 x 10 ⁴
Antimony 125	1.28 x 10 ⁴
Cesium 134	1.96 x 10 ⁴
Cesium 137	7.36 x 10 ⁵
Barium 137	6.97 x 10 ⁵
Cerium 144	1.49 x 10 ⁵
Praseodymium 144	1.49 x 10 ⁵
Promethium 147	7.23 x 10 ⁵
Europium 154	4.29 x 10 ³

Fuel Canisters

Material	SST
Weight	500 to 2000 lb
Diameter	1 ft
Length	14 ft
Closure	Welded or bolted
Quantity	250 (est.)
Storage spacing	2 ft centers
Length of storage	<u>></u> 5 years

Representative Casks

Type of carrier	Truck/railroad	Truck
Shipping cask	IF 300 Cert. No. 9001	NLI 1/2 Cert. No. 9010
Outside diameter	5-1/2 ft	4 ft
Length	17-1/2 ft	16-1/4 ft
Weight	70 tons	25 tons
Type	Top loading	Top loading
Canister loading	4	1
Gross weight-truck, cask, cradle and fuel container	100 to 105 tons	35 to 40 tons

REFERENCES

1. Metropolitan Edison Co., et al., Three Mile Island Nuclear Station, Unit 2, Final Safety Analysis Report, Docket-50320-73, April 4, 1974.
2. T. England and W. Wilson, TMI-2 Decay Power: LASL Fission Product and Actinide Decay Power Calculations for the President's Commission on the Accident at Three Mile Island, LA-8041-MS, 1979.
3. D. W. Croucher, A Basis for Tool Development for Reactor Disassembly and Defueling, GEND-007, February 1981.
4. D. E. Owen, "TMI-2 Core Examination: INEL Facilities Readiness Plan, DEO-13-82," letter, EG&G Idaho, April 1, 1982.
5. J. M. Bower "TMI Core Encapsulation--Thermal Analysis," JMB-11-82, letter, EG&G Idaho, March 26, 1982.

APPENDIX B
RADIATION FIELD FROM 250 TMI FUEL ASSEMBLIES IN CANAL

APPENDIX B^a
RADIATION FIELD FROM 250 TMI FUEL ASSEMBLIES IN CANAL

The radiation field from 250 TMI fuel assemblies has been calculated at a position 1 ft above the canal water surface. The assemblies, assumed to be 179-1/2 in. long, contain 208 fuel rods per assembly. Each assembly is contained in a canister 13-1/2 in. in diameter. The center-to-center distance between the assemblies is 18 in. The 250 assemblies were placed in two stacks of 15, per stack; each stack is five assemblies high and three wide. The two stacks are in line with an end-to-end distance of 2 ft. The depth of the water was calculated from the surface to the centerline of the top assembly. The source term for the calculation was obtained from Reference 1. The radiation field was calculated using the ISOSHLD-II computer code.² The result is graphed in Figure B-1.

The minimum depth of water required for recommended maximum exposure during handling and storage is as follows:

<u>Radiation Field</u> (mR/h)	<u>Depth</u> (ft)
500	4.2
0.1	8.8

a. Appendix B is an edited version of P. E. Wildenborg's letter to G. R./Bergland, "Radiation Field from TMI Fuel in TAN-607 storage pool," Wild-2-83, June 28, 1982.

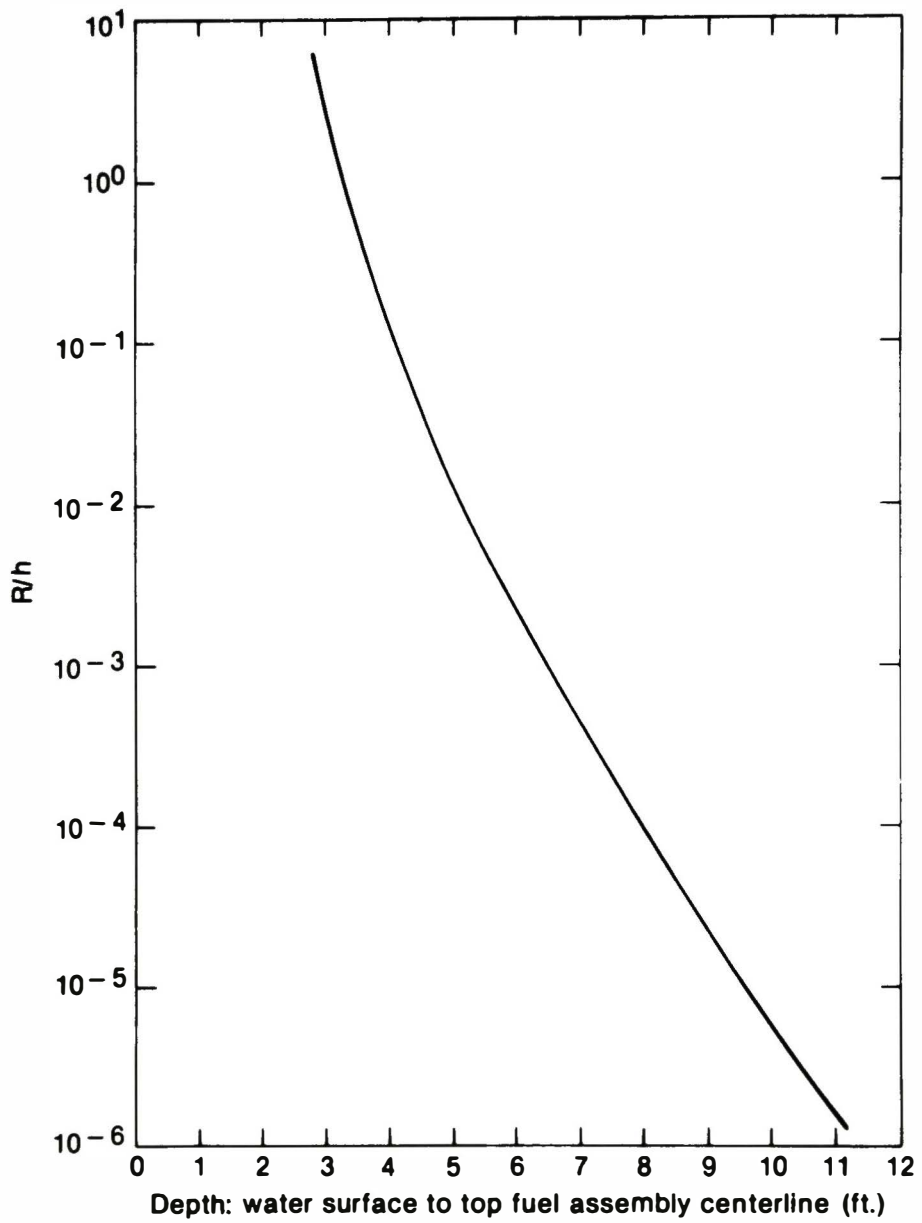

INEL 2 3299

Figure B-1. Radiation field at a point 1 ft above the water surface.

REFERENCES

1. T. R. England and W. B. Wilson, TMI-2 Decay Power: LASL Fission Product and Actinide Decay Power Calculations for the President's Commission on Actinide at Three Mile Island, LA-8041-MS, UC-78, March 1980, p. 72.
2. BNWL-236, UC-34, ISHOSHLD-II, A Computer Code for General Purpose Isotope Shielding Analysis, June 1966.

APPENDIX C
WORK BREAKDOWN STRUCTURE DICTIONARY

APPENDIX C
WORK BREAKDOWN STRUCTURE DICTIONARY

The following paragraphs discuss the tasks and elements shown in the WBS of Section 5.

Project Management

1. Project Administration provides management required to control project costs and schedule. This includes costs of preparing reports, presentation material, and travel.
2. Systems Engineering provides for the preparation, control, and integration of technical parameters to ensure compatibility of physical, functional, and program interfaces. The first year's work will be spent on trade-off studies, e.g., storage methods, seismic criteria, and requirements for individual work packages.
3. Configuration Control establishes the identification, control, and accounting for all design and performance, examination-sample, and safety documentation.
4. Quality Assurance and Safety provide for design reviews and procurement, fabrication, installation, and operations support.

Safety and Environmental

1. Environmental Assessment coordinates and prepares environmental documentation needed for the project.
2. Safety Analysis Report (SAR) will be revised to cover new operations and hazards presented by the project.
3. Operational Safety Requirements will include revisions to existing OSR defining the conditions and management controls needed for safe operation of the project.

4. Criticality Analysis is an analysis for ensuring that storage and handling of the canisters fall within criticality and safety limits.

Facility Modifications

1. TAN-607 facility modifications include the design, procurement, fabrication, and installation needed at the TAN-607 facility.
2. Other Facilities modifications are those necessary for the examination programs in facilities other than TAN-607

Operations

1. Detailed Operating Procedures and Manuals will be prepared for receiving, handling, examining, and storing the core materials. Addenda to operating manuals, SDDs, etc., will also be prepared.
2. Training will be provided to operations personnel so they will be able to receive and handle the casks, canisters, and samples required by the program.
3. Handling Tools for casks, canisters, etc. will be designed, fabricated, and tested.
4. Readiness Review will be arranged prior to receipt of the first cask to ensure facility and personnel readiness.

APPENDIX D
DESCRIPTION OF FACILITY MODIFICATIONS FOR TAN-607

APPENDIX D
DESCRIPTION OF FACILITY MODIFICATIONS FOR TAN-607

The items listed in this Appendix cover only the major upgrade, modification, and refurbishment activities. Handling devices and fixtures, and sample isolation/preparation/examination equipment in Table 2 are either self-explanatory or represent aggregates of numerous small items.

Hot Shop

100-ton Crane Electrical Control

Replace the existing ac crane control system with a dc drive system and suitable controls.

Overhead Manipulator Refurbishment

Refurbish the bridge, trolley-hoist exteriors, and Par 7000 assembly. Replace worn parts, bearings, clutches, etc. Procure and install new power-control center if required for dependable operation.

Repair Radiation Monitoring System

The present radiation monitoring system needs work to make it fully operational and maintainable. Modifications to some of the electronics are required to replace obsolete components with new off-the-shelf parts. Some of the high voltage lines need rewiring. As-building of system drawings is required.

Hot Shop Door Seal

The main door to the Hot Shop requires new seals to ensure negative-pressure air flow during operations within the facility.

Refurbish Hot Shop Utility Pedestals

The existing utility service pedestals in the Hot Shop should be refurbished so that services no longer needed can be removed and those still required can be upgraded to provide reliable performance. This would require replacing solenoid valves, piping, and electrical service connections. The existing control stations switches in the galleries and the power relay panel in the equipment room should be replaced.

Special Equipment Service (SES) Room

SES Door Seal

A seal must be provided for the main SES doors. This seal must be capable of providing a seal when the door is closed, as well as when it is open, to ensure negative-pressure airflow during operations in the Hot Shop.

SES Personnel Door Seal

The existing personnel door shall have a seal installed to assist with negative-pressure airflow.

TAN Hot Cell (THC)

Personnel Door Refurbishment

The motor drive assembly and electrical controls will be refurbished. The door-roller bearings will be replaced and a new seal installed.

Macro Examination Capability Upgrade

Provide for photography development and procure a camera with VCK. Photography work entails procurement and installation of a backlighting system for fuel bundles and for mirror photography of slabs, a process which eliminates all shadows. Provide the capability to grind and polish large samples and set up a potting system.

Automatic Welding/Canning System

Provide and install equipment in the hot cell for remotely sealing and venting canisters. This is to be used to recan sample materials for shipment to other laboratories. It includes all fixtures for handling and holding the canisters.

Sectioning Saw

Provide remote sectioning saw for cutting fuel assemblies for examination.

Fuel Storage Racks

Design and fabricate fuel-pool storage racks for an estimated 250 canisters. Racks will be modular in design. Fabrication and installation will be conducted in stages to provide for the actual number of canisters to be received. Also included in this listing are racks for storing sample materials selected and isolated for examination. These racks will be separate from the main canister storage racks, although still in the TAN storage pool, due to the anticipated smaller sample canister size.

